

Title Enhancing energy management of a car
 manufacturing plant through modelling and
 dynamic simulation

Author(s) Savolainen, Jouni; Lappalainen, Jari;
 Aikala, Antti; Ruuska, Pekka

Citation 29th European Conference on Modelling and
 Simulation, ECMS 2015, 26 - 29 May 2015,
 Albena, Bulgaria
 ECMS proceedings 2015, Pages 259-265

Date 2015

Rights This article may be downloaded for personal
 use only.

VTT
<http://www.vtt.fi>
P.O. box 1000
FI-02044 VTT
Finland

By using VTT Digital Open Access Repository you are bound by the following Terms & Conditions.

I have read and I understand the following statement:

This document is protected by copyright and other intellectual property rights, and duplication or sale of all or part of any of this document is not permitted, except duplication for research use or educational purposes in electronic or print form. You must obtain permission for any other use. Electronic or print copies may not be offered for sale.

ENHANCING ENERGY MANAGEMENT OF A CAR MANUFACTURING PLANT THROUGH MODELLING AND DYNAMIC SIMULATION

Jouni Savolainen, Jari Lappalainen, Antti Aikala and Pekka Ruuska
VTT Technical Research Centre of Finland Ltd.
P.O.Box 10000, FI-02044 VTT, Finland
E-mail: Jouni.Savolainen@vtt.fi

KEYWORDS

Car Manufacturing, Co-Generation, Energy Management, Modelling, Dynamic Process Simulation.

ABSTRACT

Car manufacturing is a significant energy consumer and it is a common practice to co-produce electricity and heat on-site. Despite of the research and development already conducted in the area, many opportunities for reducing energy use exist. By developing an intelligent Energy Management System which utilizes precise monitoring of the energy production and consumption as well as predictive optimization, remarkable savings can be achieved. Fast and appropriately accurate prediction models are needed for the optimization of the energy production and consumption. This paper presents a method for developing such prediction models through the following two steps: i) detailed dynamic first principle models are developed, ii) the detailed models are used to identify and parametrise on-line prediction models. The methodology and its application to a car factory are presented.

INTRODUCTION

Typically Energy Management Systems (EMS) either monitor and control energy generation and transmission or they focus on the energy consumption side. However, a system capable of optimizing both of these roles simultaneously would be more productive. Typically such a system covers several process areas with large number of single devices.

Every time an EMS receives new data, it should be able to evaluate a good solution within a reasonable time. Because a single EMS evaluation contains optimization of several factors, it might need even thousands of system simulations. Thus a single simulation should be done very rapidly. On the other hand, simulations must yield accurate enough estimations of the future behaviour of the system. These demands set contradictory requirements for the modelling which is the reason to approach the problem through a two-step modelling method.

This paper covers part of a research project, where an intelligent Energy Management System (iEMS) using fast models of both energy generation and consumption

processes in a large car manufacturing plant, was developed. The iEMS optimization algorithm for car factory efficiently exploits the prevailing production conditions, local weather forecasts, and the planned changes in the car production.

The energy generation processes were modelled in two consecutive steps. Firstly, a detailed dynamic mechanistic simulation model was generated including gas-fired boilers, a gas turbine, steam turbine, and the related water and flue gas paths. Secondly, the results and the structure of this first principles model were used for developing fast on-line prediction models. This two-step method was used to develop on-line models of the gas turbine and its generator, the steam turbine and its generator, the boilers, an air pre-cooler and the flue gas path. Motivation for this two-step approach was that a simulator provides a convenient development environment as well as values for variables which cannot be measured from the real process. In addition to the energy production, the iEMS utilizes also on-line models of the energy consumption of the manufacturing process and the HVAC systems of the buildings. These were developed as another task of the project and are based solely on measurement data (Kampouropoulos et al. 2014).

This paper describes the design and implementation of the energy generation models. Chapter 2 presents the development of the detailed dynamic simulation model of the energy production system, and examples of its validation. Chapter 3 illustrates through an example how it was simplified into on-line models. Chapter 4 briefly describes how the on-line models are integrated into the iEMS. Finally, Chapter 5 discusses the methodology used, draws conclusions, and gives some future implications.

This work was conducted in the EuroEnergest project (www.euroenergest.eu), funded by the European Union's 7th Framework Programme. The main goal of the project is to reduce energy consumption in car industry through exact and predictive control of on-site energy production processes (Ruuska et al., 2014). The pilot version of the system is under work at the SEAT's factory at Martorell, located on the outskirts of Barcelona, in Spain.

DETAILED DYNAMIC MODELS

As the first step of the modelling methodology, we analysed the co-generation process and built a detailed dynamic simulation model. This section describes the modelling and simulation platform, illustrates the modelling and gives examples of the model validation.

The Modelling and Simulation Platform

The first phase of the model development was executed with commercial dynamic simulation software Apros (www.apros.fi). It enables full-scale and detailed modelling of industrial processes including their automation and electrical systems. Apros has been used for almost 30 years to simulate nuclear and combustion power plants (Näveri et al., 2010), as well as other industrial processes, such as pulp and paper plants (Lappalainen et al. 2005). Apros provides many specific features, such as modelling of power grids, and taking into account weather conditions in the simulations. This kind of plant scale dynamic process simulation is typically utilized in evaluation of process design, analysis of the system operation, development and testing of the controls, or training of operators. Apros models typically include also automation and the electrical systems. The model libraries have been comprehensively validated against data from physical process experiments. Apros simulator was chosen as the tool after a review of 15 simulators which were assessed on 30 criteria.

Input data for the modelling are mostly derived from P&I diagrams presenting the process connections, from physical dimensions of process equipment and pipelines, as well as equipment-specific parameters. The model is configured graphically. An example of a model diagram as it is shown on the Apros user's interface is presented in Figure 1. The process was modelled using a dynamic one-dimensional pressure-flow model which utilizes dynamic conservation equations of mass, energy and momentum to calculate flows, temperatures, concentrations and pressures in

the system. Equipment such as pumps and valves affect these equations through the source terms. A more detailed description of the models can be found in (Silvennoinen et al., 1989) and on www.apros.fi. The fact that the simulation is based on first principles of physics also allows extending the analysis beyond the original measurement data's range. We utilized these characteristics of the simulation models in order to generate source data for the development of the final on-line models.

Modelling Procedure

The modelling of the co-generation plant was based mainly on process flow sheets, control display printouts and discussions with plant engineers. Figure 1 and Figure 2 show example views of the model configuration from the Apros user's interface. In Figure 1 ambient air flowing in from left is cooled and compressed. It is mixed with natural gas as combustion takes place. The hot flue gases are used to produce electricity with a turbine and generator. In Figure 2 the flue gas goes from left to right through a heater, post-combustion chamber, superheater, evaporator, economizer and then upwards and to the stack through a recovery heat exchanger. The feed water tank and flow line is shown on the bottom right corner. The water-steam part of the gas turbine and steam turbine process was modelled using a two-phase flow model (so called 6 equation model) while air inlet, the flue gas path, heat recovery system's and boilers' water side, and superheated water system were modelled with the homogenous flow model (so called 3 equation model). The major dynamics in the model come from the volumes of pipes, ducts, tanks as well as heat structures, such as heat exchangers and metal walls of the various flow channels. All major lines of the co-generation process were modelled with appropriate piping equipment, such as valves, pumps and others. The model includes also 25 main control loops making the model operation closely similar to real plant operation.

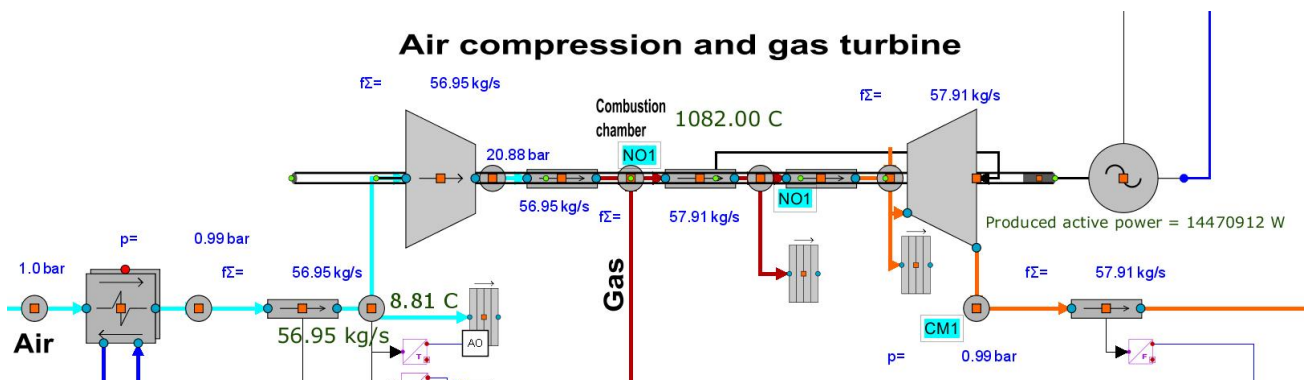

Figure 1: The Gas Turbine Process as Apros Displays it

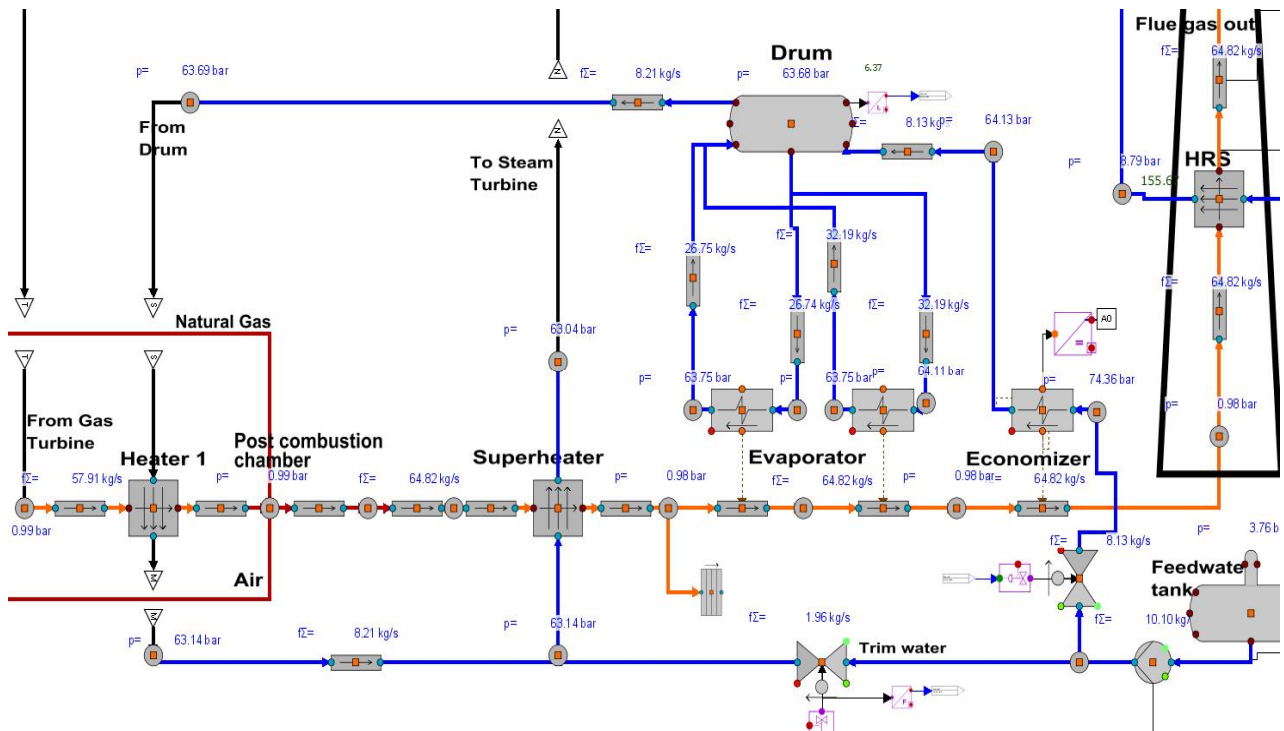

Figure 2: The Flue Gas Path as Shown by Apros

Model Validation

Models always need tuning and validation before they can be trusted as a reliable tool. When the simulation results are compared with measured data from the real system, the simulation model's accuracy can be estimated, and consequently, needed improvements in the model structure and parameters are done. Sometimes this procedure also reveals errors in the actual measurements which may bring substantial additional benefits for the project. Through an iterative process the model parameters can be adjusted and finally the simulations can predict the real system's behaviour closely enough.

The model was tested with two measurement data sets, and consequently, improvements to the process and control model's parameters were made. The final, detailed co-generation model includes a single model configuration and two initial states. The initial states correspond to the conditions in the beginning of the two validation periods.

Figure 3 and Figure 4 show the main outputs of the co-generation simulation: the temperature in the hot water stream and the generated electric powers. In the figures, solid lines are measured values and dotted lines are the corresponding simulated values. The results

obtained proved the simulation model's capability to predict the dynamic behaviour of the system and it was concluded that the model was ready for use as a virtual development and test bench for the final on-line models.

ON-LINE MODELS

The on-line nature put forth certain requirements for the models employed in the iEMS. Firstly, their computational load should be low. Secondly, they should utilize measured data from the plant, if possible. Thirdly, and most importantly, they should calculate the crucial variables which the optimization algorithm requires.

Modelling Procedure

As described above a comprehensive simulator model of the energy production system was constructed using the Apros simulator. Full scale mechanistic simulation was known right from the start of the project to be too computationally heavy to be directly used in on-line optimization. Thus, Apros modelling was used as an additional data source for constructing the on-line models. The rationale was that, if and when, actual measurements are not enough, the Apros model, which stems from the first principles of physics, could be used in addition.

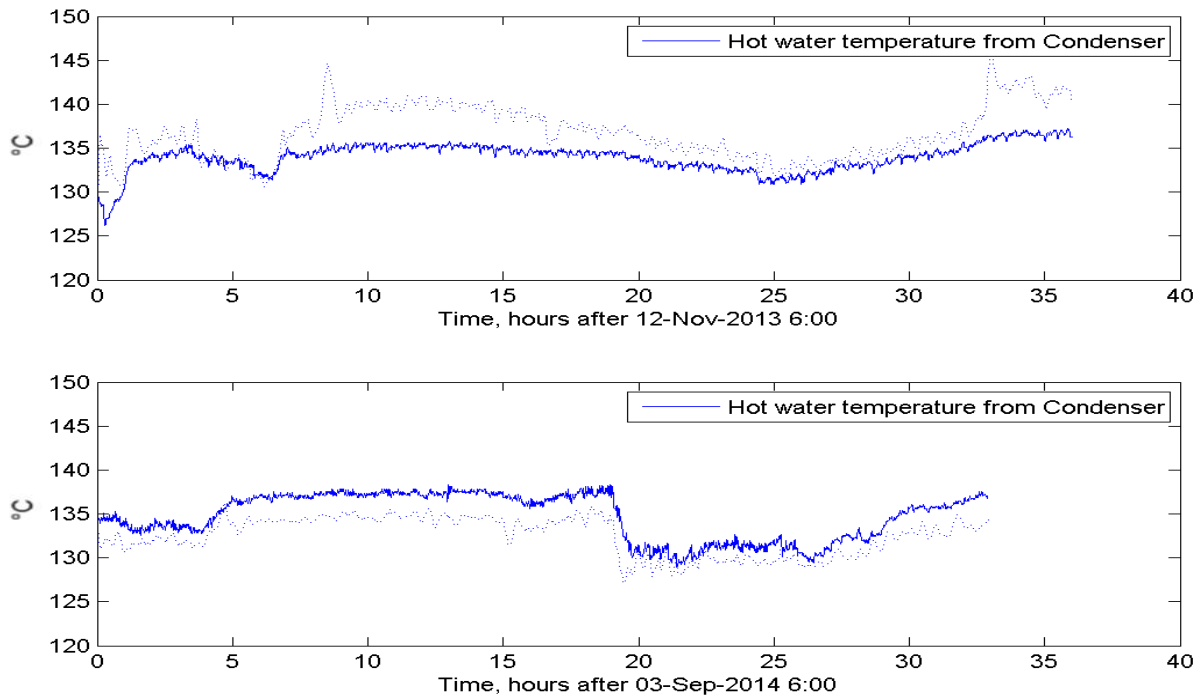

Figure 3: Calculated and Measured Temperatures of the Hot Water Flow from the Steam Condenser (solid = measured, dotted = simulated)

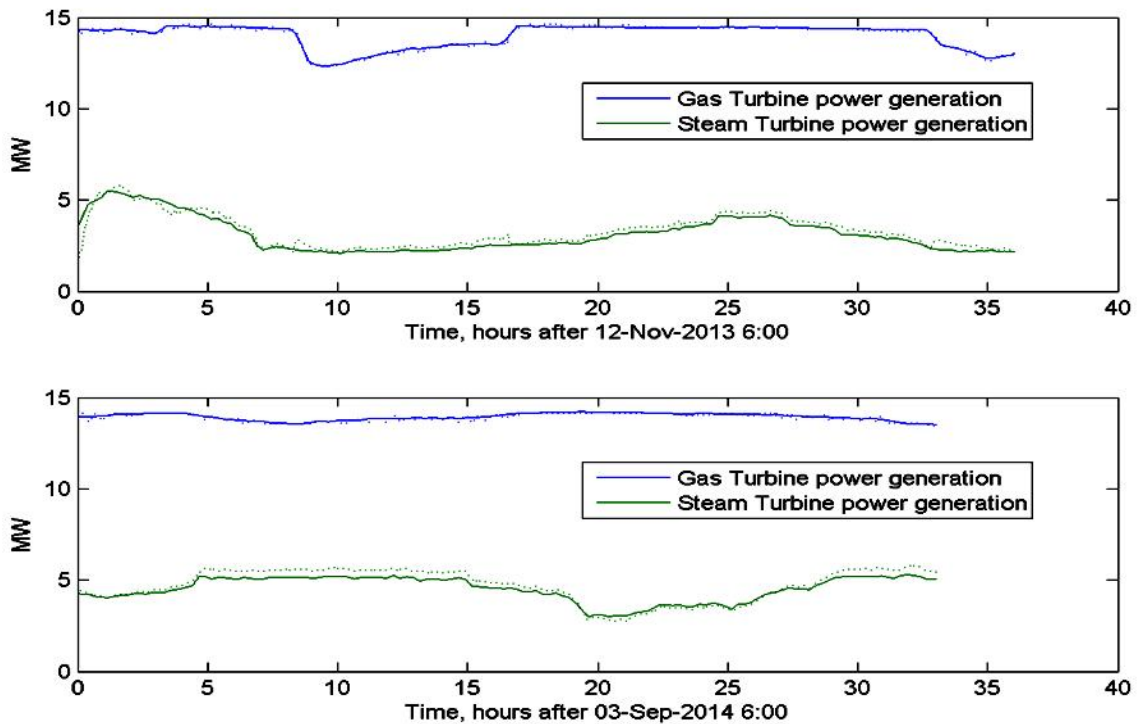

Figure 4: Calculated and Measured Electric Power Production Rates (solid = measured, dotted = simulated)

The on-line models were designed to be modular i.e. one sub-model described one limited part of the whole energy production system. Still, all of the sub-models were implemented with a similar function interface shown in Equation (1).

$$[t_{out}, y, c_{out}, x_{out}] = f_k(u, m, d, c_{in}, t_{in}, \Delta t, x_{in}) \quad (1)$$

where

- k is an index enumerating the sub-models
- t_{out} is a vector of time instance at which the outputs are evaluated
- y is a time series matrix of model outputs to the optimizer
- c_{out} is a time series matrix of model outputs to other sub-models
- x_{out} is a vector of the model's state variables evaluated at t_{out} 's last time instant
- u is a time series matrix of the future inputs from the optimizer to the model
- m is a time series matrix of the predicted future measurements to the model
- d is a vector of constant parameters
- c_{in} is a time series matrix of inputs from other sub-models
- t_{in} is a vector of time instants at which the function's inputs have been evaluated
- Δt is the internal time step, s
- x_{in} is a vector of the model's state variables evaluated during the previous execution cycle.

The input arguments are values into the future, either predicted by the optimizer or other online models. As the measurements, m , cannot be known into the future a zero-order hold of the current value is used. The inner structure of the functions f_k differs from sub-model to sub-model. For example, if the dynamics of the sub-model were fast compared to the evaluation cycle of the iEMS (15 minutes) the model was a static one. On the other hand, the sub-systems with slower dynamics were modelled with dynamic models.

The set of on-line models is run by the iEMS once every evaluation cycle, $\Delta t_{cycle} = 15$ minutes. In each evaluation cycle all the sub-models are called according to Equation (1) several times with a smaller, internal time step, e.g. $\Delta t = 1$ second.

Example: Gas Turbine

As an example we present the model for the gas turbine and its generator. The dynamic on-line model calculates three outputs. The model structure for each of these is a Hammerstein model consisting of a static non-linear and dynamic linear part. The model estimates the future values of the electricity production rate and of the flue gas mass flow and temperature.

The model was developed by generating 60 data points with Apros by altering the natural gas feed mass flow m'_{NG} and outside air temperature T_{air} between the predefined bounds:

$$m'_{NG} = [0.4, 1.2] \text{ kgs}^{-1}$$

$$T_{air} = [5, 40] \text{ }^\circ\text{C}$$

The results were achieved from 60 simulation runs, each lasting 30 minutes (simulator clock time). At the end of each simulation run, three stabilized output variables were recorded, namely the electrical power P , the flue gas mass flow m'_{FG} and the flue gas temperature T_{FG} .

To the obtained data, three static polynomial models were fitted. Of the 60 simulations 50 were used for parameter estimation while the remaining 10 were used for model validation. The actual equations are written in terms of the turbine part load ratio:

$$PLR = P / P_{nominal} \quad (2)$$

and the temperature difference:

$$\Delta T = T_{air} - T_{nominal} \quad (3)$$

where the subscript 'nominal' denotes the dimensioning point of the turbine. These are user given parameters for the model (d in Equation (1)).

For the electrical power we utilize the energy flow (q'_{FUEL}) into the turbine by the natural gas fuel:

$$q'_{FUEL} = m'_{FG} LHV = a_1 + b_1 PLR + c_1 \Delta T \quad (4)$$

where LHV is the lower heating value of natural gas (MW/kg) while a_1 , b_1 and c_1 are adjustable parameters.

From Equations (2) and (4) we get the equation for the electrical power:

$$P = P_{nominal} ((q'_{FUEL} - a_1 - c_1 \Delta T) / b_1) \quad (5)$$

For flue gas mass flow and temperature we have:

$$m'_{FG} = a_2 + b_2 PLR + c_2 \Delta T \quad (6)$$

$$T_{FG} = a_3 + b_3 PLR + c_3 \Delta T + d_3 PLR^2 + e_3 PLR \Delta T \quad (7)$$

The parameters a_i , b_i , c_i , d_3 and e_3 were identified from the Apros data with MATLAB giving the values listed in Table 1. This table also lists the RMSE (Root Mean Square Error) and R^2 (Coefficient of Determination) of the fitting procedure.

Table 1: Parameters for the iEMS Gas Turbine's Model

	P $i = 1$	m'_{FG} $i = 2$	T_{FG} $i = 3$
a	16.58	2233	579.4
b	28.69	38.65	-200.8
c	-0.0868	-0.117	0.3678
d	-	-	46.9
e	-	-	-0.025
RMSE	0.657	0.881	3.177
R ²	0.998	0.998	0.996

The static polynomial models of equations (5) - (7) were followed by a linear first order dynamic block:

$$y_i(t) = (1 - (\tau_i/(\tau_i + \Delta t)))Y_i + \tau_i y_i(t - \Delta t)/(\tau_i + \Delta t) \quad (8)$$

where

Y_i is the output i of the static models:
 $Y = \{P, m'_{FG}, T_{FG}\}$

τ_i is a user configured time constant, s.
 Default values for the user definable time constants were identified visually from Apros simulation data:
 $\tau = [1.0, 5.0, 15.0]^T$ s.

Δt is an internal time step, s

$y_i(t - \Delta t)$ is the model output i from the previous time step

Figure 5 shows the relative errors between the APROS data and the obtained equations for the 10 validation data points. As can be seen the relative errors were typically less than 5% which was considered adequate for the iEMS system.

In the iEMS, three outputs of this gas turbine model are used for different purposes. The electrical power P is used by the optimizer whereas m'_{FG} and T_{FG} are used by a subsequent model of the flue gas path.

UTILIZATION OF THE ON-LINE MODELS

Altogether nine different on-line models of the various energy production systems were implemented with MATLAB and subsequently converted into Java .jar-files. Simultaneously, the energy consumption of two workshops, the painting workshop and the body assembling, which are also in the scope of the iEMS, were analysed and modelled. All these on-line models were integrated with an optimization algorithm (Kampouropoulos et al. 2014) into a prototype of the iEMS. The iEMS system uses the production models to calculate the current and predicted energy conversion factors (COPs or efficiencies) for the equipment. These are in turn used by an optimization algorithm to produce suggested operational actions to the plant's operators. The overall structure is detailed in (Kampouropoulos et al. 2014). The system is currently under testing at the car manufacturing plant. Its full effect to the energy consumption and to the CO₂ footprint will be shown after these consecutive tests.

CONCLUSIONS

The paper described a method and its application to a case study, where a mechanistic dynamic simulator model was developed and simulation experiments were used as an intermediate phase to create on-line prediction models for an intelligent energy management system.

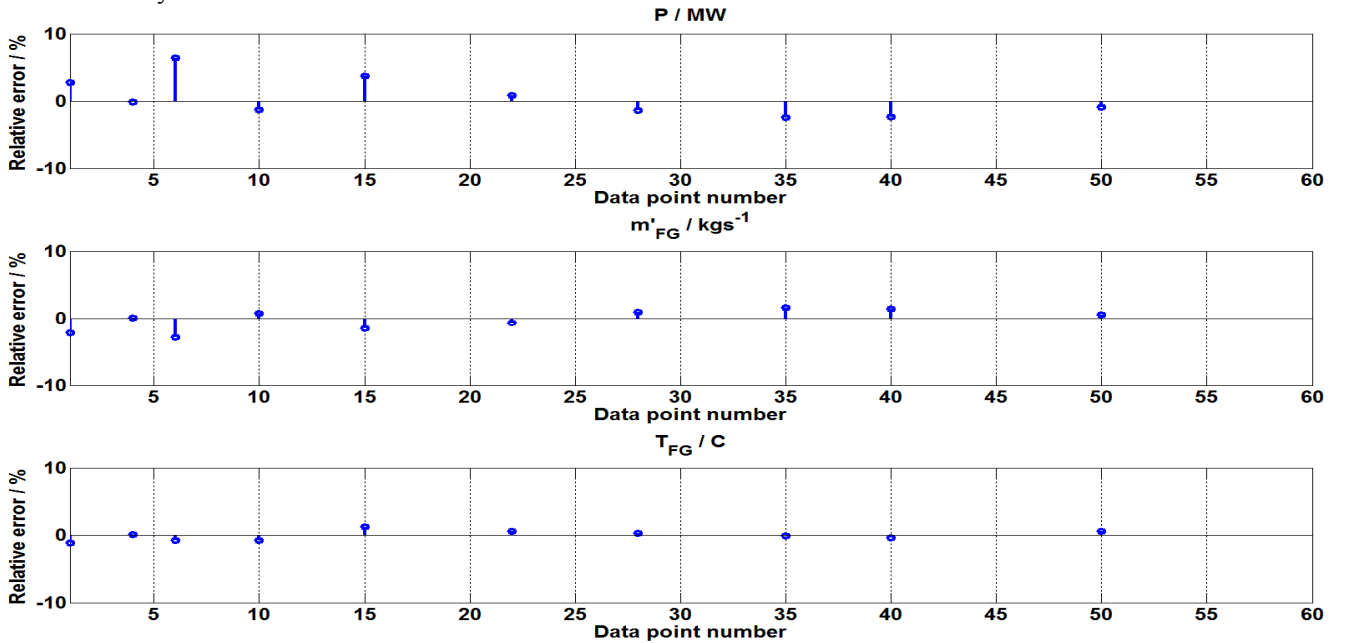

Figure 5: Relative Errors between the Calculated Values and Apros Data at Validation Data Points (%)

Configuration of the simulator model is an effort of its own and thus necessitates a careful evaluation when this approach is usable. This indeed is the case when long measurement collection campaigns are infeasible, when experimentation on the process is not possible or when measurements are scarce. The use of a simulator based on first principles of physics helps in these cases since it combines the laws of physics with actual dimensions of the process. Furthermore, performing experiments such as step tests and abnormal situations, is safe and fast using a simulator. This opens up a way for producing good on-line models. Our results show that the selected approach is capable of providing adequate on-line prediction models of energy production processes. To generalize this finding, we may argue as follows: Firstly, the simulator models are based on the laws of physics, not solely on measurements data. Secondly, the simulator used has been extensively validated and verified previously. And thirdly, the process under study is not an uncommon one. Thus, it follows that this approach is probably applicable in other cases too. When these models are integrated to an innovative version of an intelligent Energy Management System, energy saving in large-scale manufacturing processes is expected to be remarkable.

REFERENCES

- Lappalainen, J., Savolainen, J., Myller, T., Juslin, K., "Dynamic simulation studies for enhanced board machine control", *16th IFAC world congress*. Prague, 4-8 July 2005, 8 p.
- Näveri, J., Tahvonen, T., and Hakasaari, P., 2010. "Testing and Utilization of Loviisa Full Scope Apros Model in Engineering and Development Simulator." In *Proceedings of International Youth Nuclear Congress (IYNC) 2010*, Cape Town, South Africa.
- Silvennoinen, E., Juslin, K., Hänninen, M., Tiihonen, O., Kurki, J., and Porkholm, K. (1989). "The APROS software for process simulation and model development." In *VTT, No. 618*, Espoo, Finland.
- Ruuska, P., Aikala, A., and Weiss, R., 2014. "Modelling of Photovoltaic Energy Generation Systems". *ECMS 2014 Proceedings*. 651 – 656. European Council for Modelling and Simulation, Brescia, Italy.
- Kampouropoulos, K., Andrade, F., Sala, E., Romeral, L., 2014. "Optimal Control of Energy Hub Systems by Use of SQP Algorithm and Energy Prediction" *40th Annual Conference of the IEEE Industrial Electronics Society (IECON 2014)*, Dallas, USA, 29 October – 01 November 2014

AUTHOR BIOGRAPHIES

JOUNI SAVOLAINEN obtained his M.Sc. (Tech.) degree in 1999 (Chemical Engineering and Process Control) from the Helsinki University of Technology. Since then he has worked at VTT in the field of dynamic process simulation. Currently he works as a

senior scientist with an interest in coupling dynamic process simulation and other advanced applied mathematical methods. He is also managing research projects at VTT. His e-mail address is: jouni.savolainen@vtt.fi and his Web-page can be found at <http://www.vtt.fi/?land=en>

JARI LAPPALAINEN works as a Senior Scientist at VTT. He is M.Sc. and Lic.Sc. (Process control and Chemical engineering) from the Helsinki University of Technology (1993, 2003). For 15 years, he has been involved in using and developing the Apros simulation software for dynamic process simulation in various industry sectors. His major research interests include energy systems, process dynamics, process control, and modelling of material properties. His e-mail address is: jari.lappalainen@vtt.fi and his Web-page can be found at <http://www.vtt.fi/?land=en>

ANTTI AIKALA received his M. Sc. degree in Forest Products Technology, in 2000 from the Helsinki University of Technology. He has worked as a researcher first in Keskuslaboratorio Oy, a research company for Forest industries in Finland, and from 2009 as a research scientist in VTT Technical Research Centre of Finland. He has worked in areas of simulation, statistical analysis and optimization in the field of dynamic systems and processes. His e-mail address is: antti.aikala@vtt.fi and his Web-page can be found at <http://www.vtt.fi/?land=en>

PEKKA RUUSKA received his M. Sc. degree in Electrical Engineering in 1980 and Licentiate of Technology (Computer Technology) in 1993 from the University of Oulu, Finland. From 1985 he has been working with VTT Technical Research Centre of Finland. He is currently a senior scientist and his research interests are energy efficiency and renewable energy systems. His e-mail address is: Pekka.Ruuska@vtt.fi and his Web-page can be found at <http://www.vtt.fi/?land=en>