

On the reliability of fire detection and alarm systems

Exploration and analysis of data from nuclear and non-nuclear installations

Teemu Nyysönen, Jaana Rajakko & Olavi Keski-Rahkonen
VTT Building and Transport

ISBN 951-38-6569-X (URL: <http://www.vtt.fi/inf/pdf/>)
ISSN 1459-7683 (URL: <http://www.vtt.fi/inf/pdf/>)

Copyright © VTT 2005

JULKAISIJA – UTGIVARE – PUBLISHER

VTT, Vuorimiehentie 5, PL 2000, 02044 VTT
puh. vaihde 020 722 111, faksi 020 722 4374

VTT, Bergsmansvägen 5, PB 2000, 02044 VTT
tel. växel 020 722 111, fax 020 722 4374

VTT Technical Research Centre of Finland, Vuorimiehentie 5, P.O.Box 2000, FIN-02044 VTT, Finland
phone internat. +358 20 722 111, fax +358 20 722 4374

VTT Rakennus- ja yhdyskuntatekniikka, Kivimiehentie 4, PL 1803, 02044 VTT
puh. vaihde 020 722 111, faksi 020 722 4815

VTT Bygg och transport, Stenkarlsvägen 4, PB 1803, 02044 VTT
tel. växel 020 722 111, fax 020 722 4815

VTT Building and Transport, Kivimiehentie 4, P.O.Box 1803, FIN-02044 VTT, Finland
phone internat. +358 20 722 111, fax +358 20 722 4815

Published by



Series title, number and
report code of publication

VTT Working Papers
VTT-WORK-18

| | | |
|---|---|----------------------------|
| Author(s) Nyyssönen, Teemu, Rajakko, Jaana & Keski-Rahkonen, Olavi | | |
| Title On the reliability of fire detection and alarm systems Exploration and analysis of data from nuclear and non-nuclear installations | | |
| Abstract A literature review of reliability data of fire detection and alarm systems was made resulting to rough estimates of some failure frequencies. No theoretical or technical articles on the structure of reliability models of these installations were found. Inspection records of fire detection and alarm system installations by SPEK were studied, and transferred in electronic data base classifying observed failures in failure modes (59) and severity categories (3) guided by freely written records in the original data. The results of that work are presented without many comments in tabular form in this paper. A small sample of installations was collected, and number of components in them was counted to derive some distributions for determination of national populations of various components based on know total amount of installations. From NPPs (Loviisa, Olkiluoto and Barsebäck) failure reports were analysed, and observed failures of fire detection and alarm systems were classified by severity and detection mode. They are presented here in tabular form for the original and new addressable systems. Populations were counted individually, but for all installations needed documents were not available. Therefore, presented failure frequencies are just first estimates, which will be refined later. | | |
| Keywords fire detectors, fire alarm systems, failures | | |
| Activity unit VTT Building and Transport, Kivimiehentie 4, P.O.Box 1803, FIN-02044 VTT, Finland | | |
| ISBN 951-38-6569-X (URL: http://www.vtt.fi/inf/pdf/) | | Project number |
| Date January 2005 | Language English | Pages 62 p. + app. 6 p. |
| Name of project | Commissioned by Finnish Centre for Radiation and Nuclear Safety, Ministry of Trade and Industry, Fortum Engineering Ltd, Teollisuuden Voima Oy | |
| Series title and ISSN VTT Working Papers 1459-7683 (URL: http://www.vtt.fi/inf/pdf/) | Publisher VTT Information Service P.O. Box 2000, FIN-02044 VTT, Finland Phone internat. +358 20 722 4404 Fax +358 20 722 4374 | |

Preface

This study was carried out as a part of the Fire Safety Research project (FISRE) which is one of the projects in the Finnish Research Programme on Nuclear Power Plant Safety (FINNUS).

The study has been financed by the Finnish Centre for Radiation and Nuclear Safety, the Ministry of Trade and Industry, Fortum Engineering Ltd, and Teollisuuden Voima Oy. Material and immaterial deliveries from SPEK, as well as information on buildings and building fire protection devices by a considerable number of people made these studies possible. We are indebted to Mr. Yasuaki Hagimoto, National Research Institute of Police Science, Japan, for supplying Japanese reliability information articles.

Contents

| | |
|---|----|
| Preface | 4 |
| 1. Introduction..... | 9 |
| 2. Fire detection and alarm systems..... | 11 |
| 2.1 Description of the systems..... | 11 |
| 2.2 Reliability modelling of the systems | 13 |
| 2.3 Probability distributions | 18 |
| 2.4 Calculation of failure frequencies of fire detection and alarm systems and system components..... | 19 |
| 3. Literature survey on reliability of fire detection and alarm systems | 21 |
| 3.1 Numerical values of failure rates and related properties of fire detection and alarm systems | 21 |
| 4. Population and physical size of fire alarm system installations | 27 |
| 4.1 Population of fire alarm system installations | 28 |
| 4.1.1 Protected floor area in sampled buildings with fire alarm | 28 |
| 4.1.2 Fire detector density..... | 29 |
| 4.1.3 Distribution of device circuits and detectors in non-nuclear installations | 30 |
| 4.1.4 Installation age distribution in the sample of buildings | 32 |
| 4.2 Fire alarms systems in NPPs | 33 |
| 4.2.1 Distribution of device circuits in NPPs..... | 35 |
| 4.2.2 Distribution of cable length in NPPs..... | 35 |
| 5. Non-fire failure statistics..... | 37 |
| 5.1 Non-nuclear installations in Finland | 40 |
| 5.2 Non-fire failures in nuclear power plants..... | 45 |
| 5.2.1 Number of failures by categories and plants..... | 45 |
| 5.2.2 Details on critical failures | 47 |
| 5.3 Inspection time interval distribution..... | 51 |
| 6. Estimation of component failure rates | 52 |
| 6.1 Failures of fire alarm heads | 52 |
| 6.2 Failures of cables..... | 53 |
| 6.3 Failures of manual initiating devices..... | 54 |

| | |
|---|----|
| 7. Discussion and conclusions | 55 |
| 8. Summary | 57 |
| References | 58 |
| Appendices | |
| Appendix A: Detailed lists of system properties | |

List of symbols

| | |
|----------------|---|
| a | Parameter in a distribution |
| A | Floor area of a building or part of it [m ²] |
| A ₀ | Constant in equations containing floor area of a building or part of it [m ²] |
| b | Parameter in a distribution |
| BWR | Boiling water reactor |
| c | Normalisation coefficient in a distribution |
| f | Frequency of fires [1/a] |
| FMEA | Failure mode and effect analysis |
| FSAR | Final Safety Analysis Report |
| F(x) | Cumulative of a distribution of stochastic variable x |
| M | Number of counts of an object within limited bounds |
| n | Number of sprinkler heads, value of a discrete stochastic variable |
| N | Number of demands, number of observations in a sample |
| NPP | Nuclear power plant |
| p | Probability value |
| P | Probability function, potential loss |
| PWR | Pressurized water reactor |
| SPEK | Suomen pelastusalan keskusjärjestö [Finnish Fire Protection Association] |
| SVK | Suomen Vakuutusyhtiöiden Keskusliitto [Federation of Finnish Insurance Companies] |

| | |
|-----------|---|
| T | Stochastic time variable |
| TUKES | Turvatekniikan keskus [Finnish Safety Technology Authority] |
| UPS | Uninterruptable power supply |
| X | General stochastic variable |
| x | Value of a general stochastic variable |
| x_0 | Parameter in Weibull or lognormal distribution |
| z | Quantile of a cumulative distribution |
| α | Parameter in Weibull or lognormal distribution |
| β | Parameter in Weibull or lognormal distribution |
| λ | Failure rate in a distribution, $[1/a]$ |
| v | Number of degrees of freedom |

1. Introduction

In the Finnish nuclear research program FINNUS the general goal of fire project FISRE was to develop fire risk analysis further towards full and quantitative living PSA. A special emphasis was placed to improve calculation tools used to support PSA-analyses. This goal was approached on three fronts: (a) experiments and modelling on hardware, (b) software development and assessment, as well as (c) processing of statistical information (Keski-Rahkonen 2000, 2002). Project FISRE was organised into three subprojects the titles of which cover roughly the fronts mentioned above. The last of them was 'active fire protection equipment', which was further divided into two parts: reliability of (1) fire detection and (2) sprinkler extinguishing systems. This task concentrated on front (c). Laborious data mining and population counting of the task was carried out in two master's theses (Nyyssönen 2002, Rajakko 2002). This paper analyses further the data obtained, and summarises the state of art of this project, which as a scientific and technical problem needs further efforts.

A short history on the development of fire-PSA methods was given on the final report on sprinklers in FISRE-project (Rönty et al. 2004). Rather much of statements given there on the general reliability modelling and statistical analyses of sprinkler installations apply as well on fire detection and alarming systems.

Fire detection and alarming systems are considered effective means of automatic information of potential fire spread in industrial buildings. Surprisingly, their effectiveness in terms of reliability theory is not very well established in scientific sense, since reliable data on the performance are very limited. The existing references are either obsolete (Kingswell 1972, Sayers 1972, Watanabe 1979, Moliere 1982, Krasner et al. 1985, Finucane & Pinkney 1989), of limited utility for a real system design (T-Book 1992, OREDA 1992) or both (WASH-1400, 1975; McCormick 1981, Green 1982).

Ramachandran showed indirectly the reliability of fire alarming systems by studying statistically fire losses in different premises in UK (Ramachandran 1980, 1981a,b, 1992, 1993, Ramachandran & Chandler 1984). His recent monograph (Ramachandran 1998) summarises these demonstrations on the value of fire detection and alarming systems. Despite these economical assurances from system reliability point of view it is not sufficient to know, that fire alarming system decreases fire losses. During the system design phase quantitative analysis of system availability performance can be used to identify and quantify both components dominating the risk and components with marginal impact on system availability. Both of these foundations are potential targets for system re-design. However, availability analysis of any technical system calls for

component or at least sub-system level information about failure frequencies and down times.

Ramachandran (1999) also presented a model of false alarm discrimination in a very simple system. Bukowski et al. (1999) has presented a review of fire protection systems but do not present much new data.

The purpose of the present study is to carry out a kind of failure mode and effect analysis (FMEA) of detection and alarming systems starting from the component level ("the bottom-up approach") (Høyland & Rausand 1994). The scope is preliminary data analysis of these systems in Finnish nuclear power plants by studying relevant collected maintenance reports from their whole lifetime. Since the studied population is very small, probability to observe rare events from such material is still rather small, the population of components was enlarged in two other directions: (i) a Swedish nuclear power plant, and (ii) Finnish non-nuclear fire detection and alarming systems installations, which might be different from nuclear applications, but as a much larger population offer still a relevant reference.

2. Fire detection and alarm systems

Fire detection and alarm system is an installation, which notifies promptly of fire ignitions as well as the most modern installations on other adverse conditions and trouble decimating the performance of the system. Here only the very simplified version of the large variety of these systems is described to provide the basic system hardware background needed to read this report.

2.1 Description of the systems

Basic structure of fire detection and alarm systems is given in Figures 1 to 3. The main components of the system are control unit, initiating devices, manual fire alarm boxes, notification appliances, main and standby power supplies, wiring of the alarm circuits, signalling line to municipal central station, and installation layout charts (Wilson 1997). The oldest systems, where alarm is caused by opening or shunting a alarm circuit, are not shown, because they are no more installed. In more modern installations one or several alarm initiating device circuits are connected to a control unit. One circuit covers a certain part of a building, on which all initiating devices in that area are connected. In local-energy type alarm system initiating devices are galvanically connected to a two-wire circuit, which has an end-of -line resistor. The circuit operates on non-energized principle. Triggering of an initiating device mechanically or electrically shunts this line causing an alarm. In systems with signalling line circuits initiating devices are addressable and two-way communication takes place. Control panel electronics polls out periodically at a proper frequency the status of the device: operation, service, trouble, fire. Although the devices may be connected physically to the same electrical circuit, they can be programmed into arbitrary configurations of groups. Installation layout charts are floor plan drawings of the building indicating the location of alarm control panel, access routes, and locations of alarming devices or circuits. These layout charts make possible quick location of fire in the building. Fire alarm system control unit/panel notifies fire ignition ant its location, monitors system condition, supervises actions needed or auxiliary devices, and transmits alarm to the facility/central station. Systems with signalling line circuits have usually a central computer controlled supervisory panel, into which one or multiple fire alarm panels are connected.

In Figure 1 (Öystilä 1990) is shown a two wire circuit with normally open contact initiating devices, a stub line circuit (loop), or Class B in terms of NFPA 72. In Figure 2 (Öystilä 1990) a loop line circuit system is described consisting of control unit, automatic and manual adressable initiating devices (in manufacturer's vernacular: fire alarm bushbuttons, manual call points), and a stub line subcircuit. In Figure 3 (SM A41)

on the bottom of the control panel main power supply with a UPS consisting of standby batteries is indicated. On the left hand side are the circuits with various initiating devices, and on the right hand side notification devices, signal transmission to control center, as well as control signal lines to auxiliary fire protection systems.

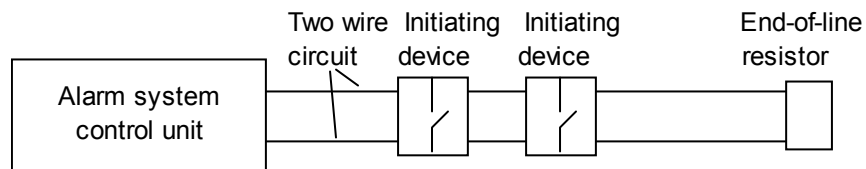

Figure 1. Principal structure and components of a stub line (Class B in NFPA 72) fire alarm system (Öystilä 1990).

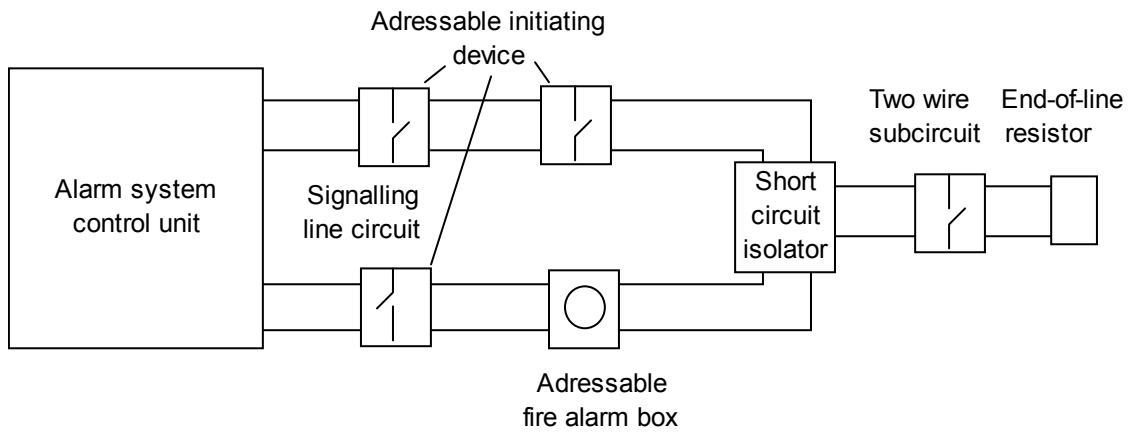

Figure 2. Principal structure and components of a loop line fire detection and alarm system with a stub line subcircuit (Öystilä 1990).

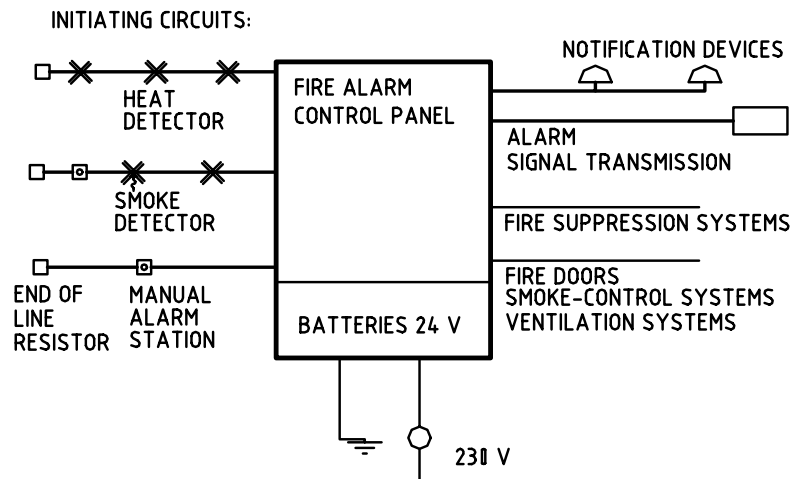

Figure 3. Principal structure of a fire detection and alarming system with alarm transmission, notification devices and control signals to auxiliary fire protection systems (SM A41).

2.2 Reliability modelling of the systems

From the reliability point of view the fire detection system differs from many of the more common systems, because it is distributed in space or rather areawise. If you look a pump: there is a definite place for material intake, and another for output. If the pump cannot move material between these two well defined locations when required, pump fails. A fire alarming system is a multiple entry 'pump'. If one detector does not respond, there is often another possibility through a neighbouring detector, like a pump, which is feeded from several independent inlets. The response through these neighbouring channels is generally more delayed and might be of lower probability than through the detector closest to ignition. Evaluating the performance of fire alarming installation we could have two viepoints: (i) from the operation of the system, and (ii) from the success of a single alarming mission. Failure of the mission (ii) is at least a partial failure of item (i). In this survey the major viewpoint has been item (ii) to locate critical paths in the success especially as regards performance of single components. In evaluating the performance of the system for the relevance of nuclear safety, the viewpoint must be item (i). In evaluating its performance further modelling is needed to transform a distributed system to a effective simpler system, where local failures of item (ii) are given weights relative to their areas of influence in the total system. This modelling can be made only after we have some preliminary quantitative information from item (ii). In constrast to sprinkler installations (Rönty et al. 2004), which is also a distributed system, there are not yet available statistical data, which tells, how many detectors respond to a single fire.

From viewpoint (ii) looking a single fire event in a given location close to an initiating device successful fire detection and alarming requires faultless operation of a number of components coupled in series. Therefore, for assessing the failure of the mission, a 'fault three' through an OR gate results as given in Figure 4. This tree is for demonstration of the dependencies, and not strictly a fault tree in the mathematical sense, since the number of components in various barances or even within a branch are not the same. Once some numerical values of somponent or subsystem performance are available, approximate real fault trees can be built. The same also applies to all other 'fault trees' presented later in this paper.

From left to right in Figure 4 the six subsystems are: (1) detector failure (Det), (2) failure of alarm system component (Comp), (3) signal communication subsystem failure (Comm), (4) failure in auxiliary control subsystems (Control), (5) power supply failures (PS), and (6) failures resulting in false alarms (False) (in parentheses short names of the subsystems to be used below).

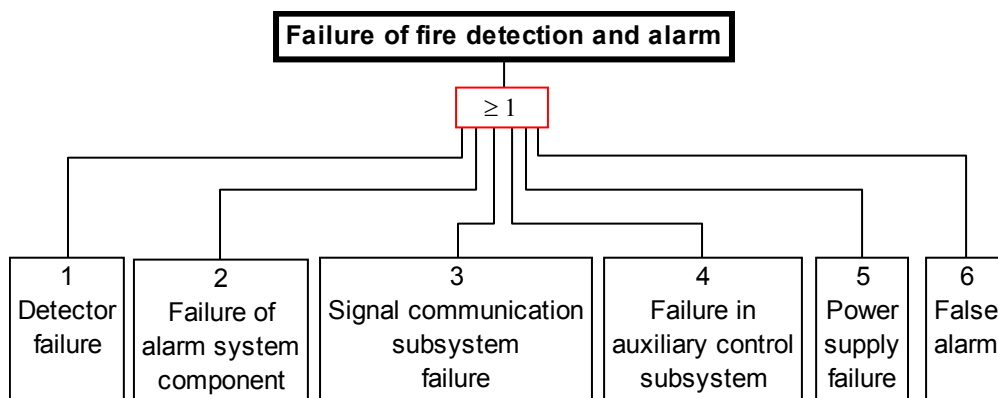

Figure 4. Fault tree of fire detection and alarming system divided into six subunits by cause of failure.

Each of these six subunits can be divided further down. Guided by statistics available the first guess was to include one or two more levels as indicated in detail in Figures 5 to 9. In fire detection systems the most common component is the initiating device, fire detector. There are several kinds of these detectors, but for NPPs they are not counted separately in this paper although this information is available from the raw data sorted and stored. All failures related to detectors are counted into this category except loosening, bad connection and wrong installation of a detector, which are recorded as communication failures. The most common failure is a dirty smoke detector. Dust and other dirt accumulates on smoke detectors requiring cleaning at given intervals. The addressable fire detectors have a built-in calibration, which maintains detector sensitivity despite soiling and dirt.

This modelling of the systems is the first guess and first round in a series of approximations needed. It is mainly intended to represent in a graphical way the complicated groups of failures in the systems. Since there is quite a variation in the electrical and electronic structure of the systems, it is not feasible to try a detailed modelling of the system availability starting from discrete components coupled to each other according to circuit diagrams. Instead, an average way of presentation is attempted, where the smallest subunits are some functional parts of the system. How far in detail this modelling is possible or rather feasible, depends on available statistical data. Borrowing mathematical terms the fault trees presented here are an ansatz in the first round of iteration. Once failure frequencies of the proposed subunits have been determined from statistics, the fault trees has to be redesigned for engineering purposes taken the statistical material available. This type of modelling does not include all the deterministic information in the systems potentially available, but tries to reach the practical level of detail, which is limited by statistical information of the failure causes.

The subunits of detector failure in Figure 5 are (1.1) dirty, (1.2) faulty, and (1.3) wet detector. These are again divided into two to four subunits as given in the fault tree boxes. In the raw material division was made down to this level, if need information was available. Since the number of failure was a few hundreds per system at maximum, division to this third level turned out to be too fine a division. Thus here we make summaries including the first two levels only. Going further towards viewpoint (i) detector failure fault tree of Figure 5 should be modified to allow several parallel detectors.

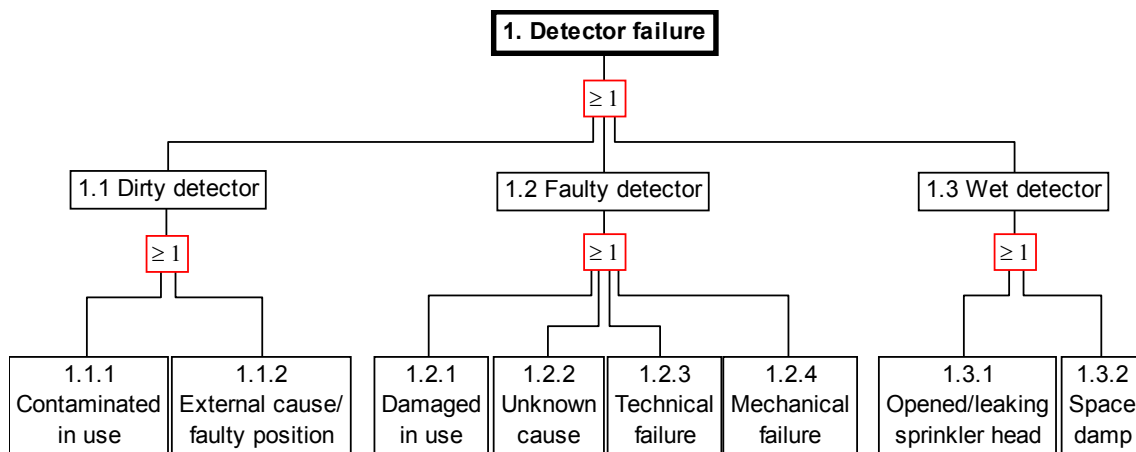

Figure 5. Fault tree of detector failure.

Failures of alarm system 'components' shown in Figure 6 include failures of all components of the system except detectors, which is a separate subunit (Figure 5), and failures of cables, which are included in communication failures of Figure 7. The subunits are (2.1) mechanical failures in control panel, (2.2) electrical or electronic

component failures (including programming failures) in control unit, and (2.3) failures in manual initiating devices. Again a third level is indicated in Figure 6 and used in sorting original data, but is not reported for the same reason as given above. Ageing is one contributor to 'component' failures, which is observed especially for manual fire alarm boxes, and various indicating bulbs.

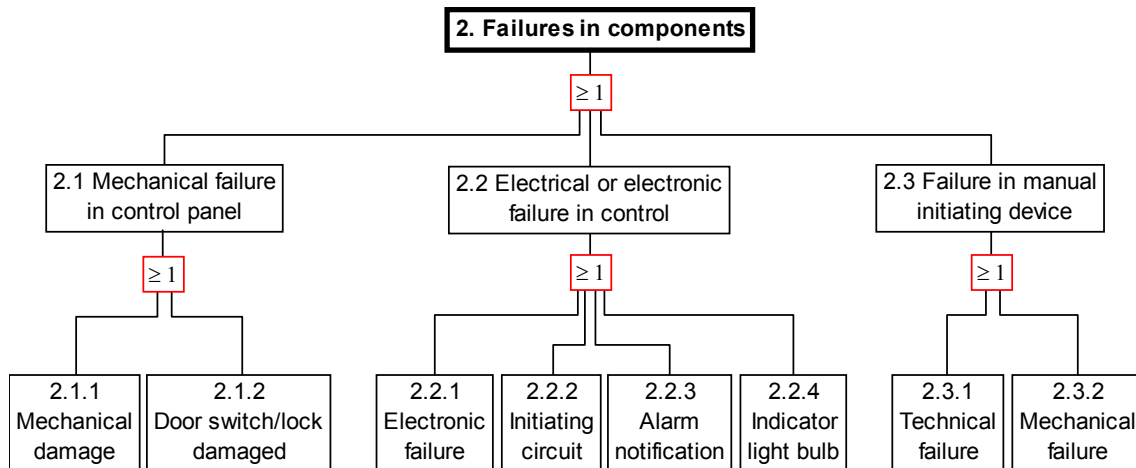

Figure 6. Fault tree of failures in alarm panel 'components'.

In Figure 7 signal communication failures are divided into five subgroups: (3.1) wire/cable failure, (3.2) no/bad connection to a detector, (3.3) announcement forwarding, (3.4) removed circuit, and (3.5) ground short. For the third level the same comments as above. Communication failures in Figure 7 include wire/cable failures, which in old alarm circuits lead easily to critical failures. In addressable systems part of the alarm circuits have been replaced by a network of cables. Therefore, loss of one cable does not necessarily mean a severe failure in the system. For that part the fault tree of Figure 7 is not quite right. It is not changed either, because it is easier to take that phenomenon into account by classifying the effect of the failure, than to change the fault tree.

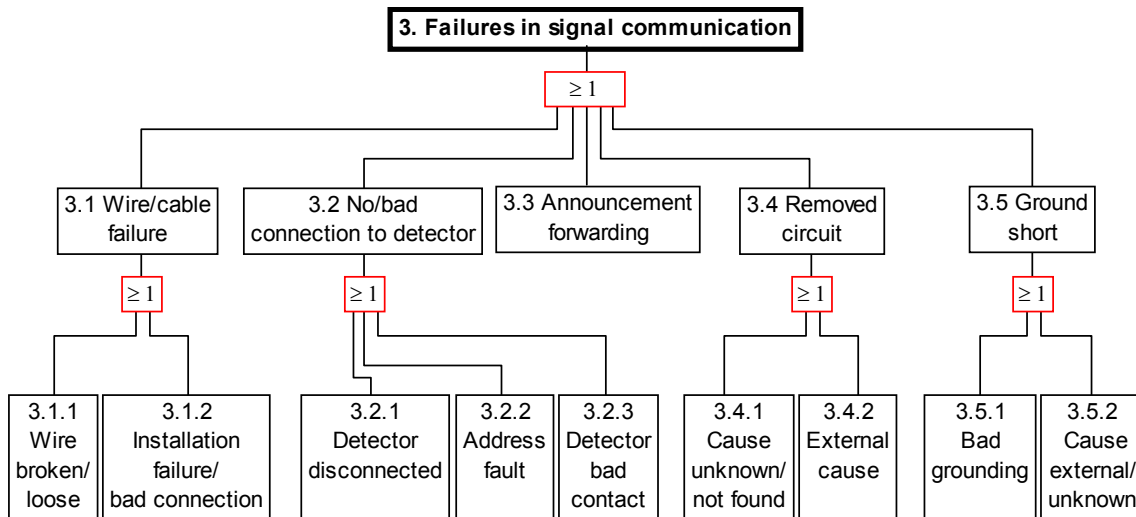

Figure 7. Fault tree of failures in signal communication subsystem.

Failures in auxiliary control subsystems in Figure 8 are subdivided to five groups: (4.1) failures in computers/coding including all computer code errors throughout the system with the exception of single detectors, (4.2) failures in controls of fire dampers, (4.3) extinguishing systems, (4.4) pumps, and (4.5) alarming/notification appliances.

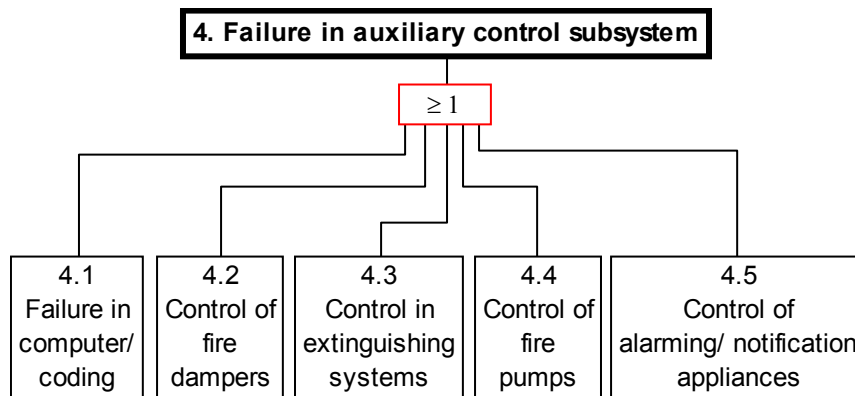

Figure 8. Fault tree of failures in auxiliary control subsystems.

Failures in power supply are divided into three subgroups in Figure 9: (5.1) failures in mains voltage or circuit current, (5.2) failures in standby power batteries, and (5.3) faulty component/connection.

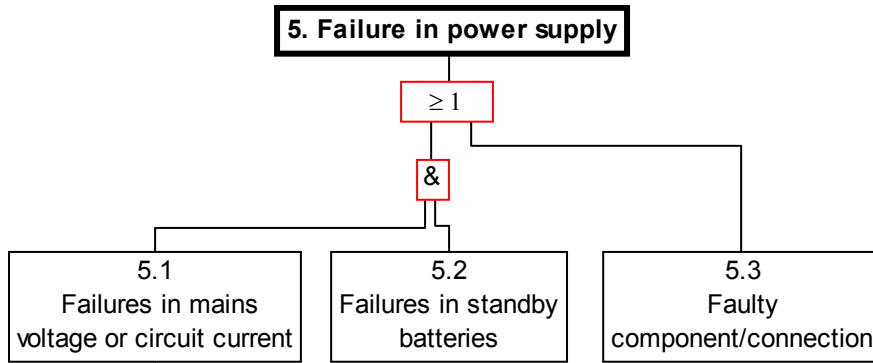

Figure 9. Fault tree of power supply failure.

Failures resulting in false alarms are collected in Figure 10 in two subunits: (6.1) human error, and (6.2) instruction error. Human errors consist of (6.1.1) communication, (6.1.2) control and (6.1.3) testing errors, whereas instruction errors are divided into (6.2.1) insufficient/faulty guidance/data, and (6.2.2) design error or modification.

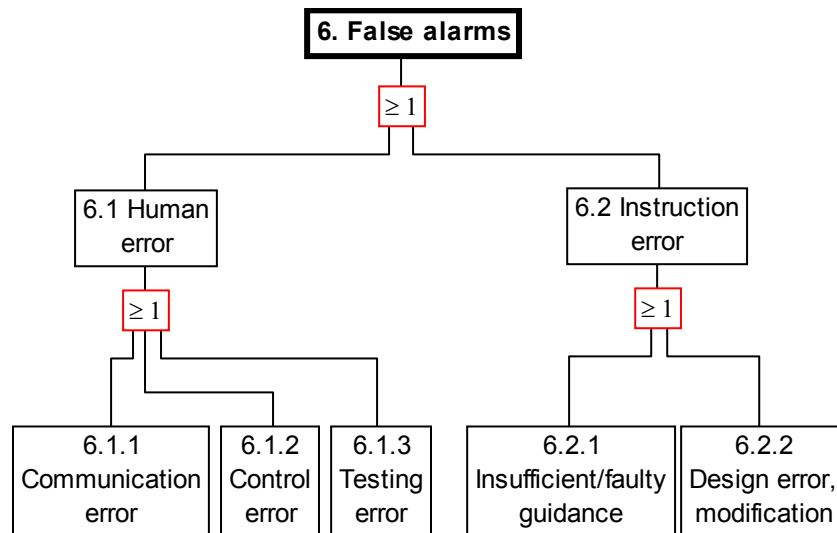

Figure 10. Fault tree by cause of failures resulting in false alarms.

2.3 Probability distributions

In this study several variables can be considered stochastic. A Weibull distribution is quite often an approximate description of observations. Its cumulative distribution as a function of x is given mathematically by (McCormick 1981)

$$F(x - x_0) = 1 - \exp\left\{-[(x - x_0) / \beta]^\alpha\right\} \quad \alpha > 0, \beta > 0, \quad 0 \leq x_0 \leq x \leq \infty \quad (1)$$

where x_0 , α , and β are parameters to be determined from available data. Another distribution encountered (McCormick 1981) is a lognormal distribution with a cumulative function

$$F(x - x_0) = \begin{cases} \frac{1}{2}(1 - \operatorname{erf}|z|), & x - x_0 < \beta \\ \frac{1}{2}(1 + \operatorname{erf}|z|), & x - x_0 > \beta \end{cases} \quad (2)$$

and where

$$z = \frac{\ln[(x - x_0) / \beta]}{\sqrt{2} \alpha} \quad \alpha > 0, \beta > 0, \quad 0 \leq x_0 \leq x \leq \infty \quad (3)$$

For cumulative estimates median ranks were used throughout (McCormick 1981).

2.4 Calculation of failure frequencies of fire detection and alarm systems and system components

The systems are presumed to have a constant failure rate λ , the number of failures X within a given time interval T is Poisson-distributed random variable (OREDA 1992). An estimator for the failure rate is given by

$$\hat{\lambda} = \frac{X}{T} \quad (4)$$

and the 90% confidence interval for $\hat{\lambda}$

$$P\left(\frac{1}{2T} z_{0.05, 2N} < \hat{\lambda} < \frac{1}{2T} z_{0.95, 2(N+1)}\right) = 0.90 \quad (5)$$

where $z_{\alpha, \nu}$ denotes the lower 100α percentile in a χ^2 -distribution with ν degrees of freedom (Abramowitz & Stegun 1970). The circumflex on the symbol means an estimated value. If no failures occur in the given time interval the upper 90% confidence estimate for the frequency is given by

$$P\left(\hat{\lambda} < \frac{1}{2T} z_{0.9, 2} \approx \frac{2.302588}{T}\right) = 0.90 \quad (6)$$

For estimation of constant demand probability p for a particular failure mode, within a period of event data surveillance a total number of N demands are made. If failures are

independent, the number of failures X is a stochastic variable with a binomial distribution. Maximum likelihood estimator for p yields (OREDA 1992)

$$\hat{p} = \frac{x}{N} \quad (7)$$

where lower p_{min} and upper p_{max} bounds at 90% confidence intervals are given by

$$p_{min} = x / \{x + (N - x + 1) f_{0.95, 2(N-x+1), 2x}\} \quad (8)$$

$$p_{max} = (x + 1) f_{0.95, 2(x+1), 2(N-x)} / \{N - x + (x + 1) f_{0.95, 2(x+1), 2(N-x)}\} \quad (9)$$

f_{α, ν_1, ν_2} is the 100α percentile in a Fisher distribution with ν_1 and ν_2 degrees of freedom (Abramowitz & Stegun 1970). If no failures occur in the given time interval the upper 90% confidence estimate for the probability is given by

$$p_{max} = f_{0.9, 2, 2N} / \{N + f_{0.9, 2, 2N}\} \approx \chi_2^2 / \{N + \chi_2^2\} \approx 2.302588 / \{N + 2.302588\} \quad (10)$$

where the approximate numerical estimate is valid, when N is large (>30).

The error bars in figures where direct counts are made indicate statistical fluctuations only. They are calculated here and on most of the rest of this paper from the error formula of Poisson distribution. If in a group within a collection period M observations are made, the standard deviation of random statistical fluctuations becomes \sqrt{M} , which is asymptotically valid for $M > 10$, (Beers 1953).

3. Literature survey on reliability of fire detection and alarm systems

Fire risk analysis on nuclear installations has been practised since the Rasmussen report (WASH-1400,1975), and in fact the best references are already aged as the state-of-the-art report confirms conclusively, (CSNI 2000). A literature study on reliability of fire detection and alarming systems was started by a search in relevant data bases. Since the results were not very good, it was continued contacting personally some people, which were thought to have available important sources. This way some of the most relevant references were found. The reason is that results are generally not published in books or major periodicals but in laboratory reports and internal series, which do not often find way to general data bases.

3.1 Numerical values of failure rates and related properties of fire detection and alarm systems

UL 217 requires for smoke detectors electronics circuitry failure rate better than 0.035/a (Cholin 1997). Inspection schedule is determined by NFPA 72, but on what it is based on, is not given.

Early theoretical models of the interdependence of detection time and noise level of fire detectors was depicted by Luck (1972), where it was shown through numerical examples, what are the major components contributing to false alarms. A typical false alarm rate per a single detector is 0.01/a, (Luck 1986). In reality the actual false alarm rate is much bigger than this, and therefore special efforts are needed to reduce it.

Gupta (1984/85) analyses real on-line observations of false alarms from 6 different sites. He finds the time between false non-fire observation follows roughly a Weibull distribution. The cumulative distribution of time intervals between false alarms is given by Equation (1) (in two parameter form: $x_0 = 0$ d), where x is the time in days [d]. Reasonable fits were obtained for typical parameters: $\alpha = 0.7 \dots 1.1$, and $\beta = 5 \dots 40$ d. In the report the problem is not properly described, and therefore, also the scale parameter β has no real quantitative meaning, because the sizes of the systems are not given.

For a single site Gupta (1984/85) is more specific: he obtained failure rates for hardware from a hospital with totally of 572 ionisation type smoke detectors. The results are given in Table 1.

Table 1. Failure and false alarm rates (per device year [1/a]) of ionisation detectors in a hospital (Gupta 1984/85).

| Type of failure | Failure rates [1/a] | | |
|----------------------|---------------------|-----------|-------------|
| | safe | dangerous | false alarm |
| Ionisation detectors | 7.0E-5 | 3.0E-5 | 8.0E-4 |

Although the residential fire alarms are not exactly comparable with the systems studied here, it is no irrelevant to pay some attention to them because of their very large population as compared to more sophisticated fire alarming systems. *A priori* one could expect that the performance of residential alarms give valuable information on fire-detector interaction, which is poorly known from NPP environment due to low number of incidents. For the reliability of fire alarms in residential premises one of the best series of information is available from the UK, although it is not a direct count but based on weighed samples.

Table 2. Average UK numbers of fires and casualties in dwellings 1997 - 2001 (Watson et al. 2000, FS 2002).

| | | Detector present, operated & raised alarm | Detector present, but did not raise alarm | Present, but did not operate | Absent |
|------------------|-------------------------------|---|---|------------------------------|--------|
| Fires | Average number | 16 324 | 2 591 | 7 179 | 45 034 |
| | In per cent of total | 22.9 | 3.6 | 10.1 | 63.2 |
| | In per cent of alarms present | 62.3 | 9.9 | 27.3 | |
| Fatal casualties | Average number | 54 | 30 | 86 | 324 |
| | In per cent of total | 10.9 | 6.1 | 17.4 | 65.7 |
| | Probability per fire (%) | 0.33 (0.46) | 1.16 (1.61) | 1.19 (1.66) | 0.72 |

In Figure 11 a fault tree of fire detection systems is presented based on a study of maintenance records of 777 Japanese fires at different installations (Watanabe 1979). Watanabe uses for the system three different probability concepts

- reliability: probability of performing the specified function under specified conditions for a specified time without failure,
- capability: probability of achieving the operational demand under specified conditions satisfactorily, and
- availability: probability of operating satisfactorily at any given time under specified conditions.

The effectiveness of the system is the product of these three factors. The total fire detector system reliability was 0.987, capability (design adequacy) 0.939, and availability 0.970 leading to total effectiveness of 0.89. There is no explanation in the short article, how these figures were obtained. Figure 11 gives in detail, which are the biggest sources of faults in the installations. Contribution to total inefficiency is given in Figure 11 in %. There is no description on the type of buildings used in this study, but a vague hint on high rise. Therefore, the use of these figures is limited, but the model used is general in principle.

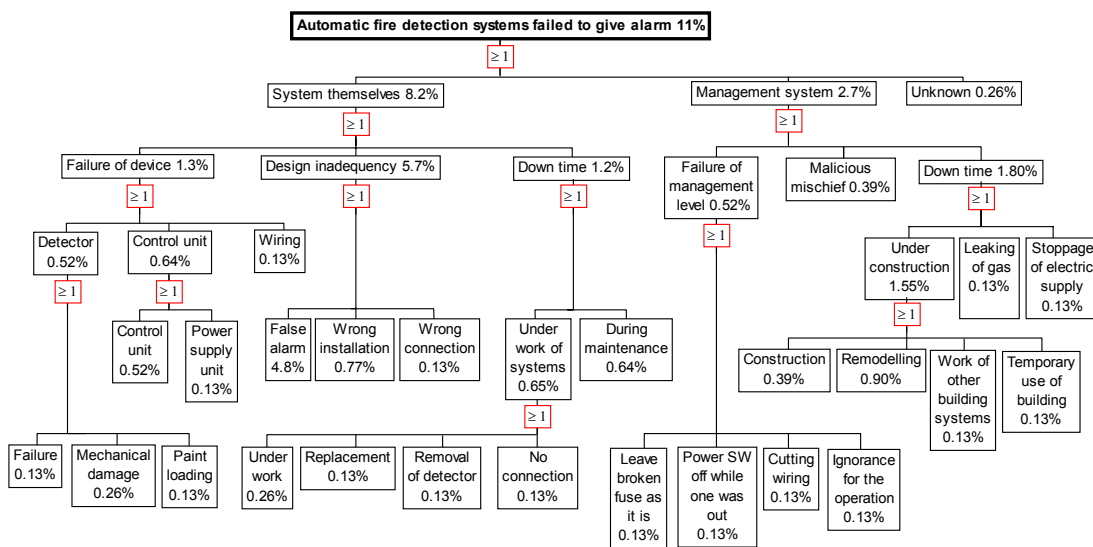

Figure 11. A fault tree of fire detection systems presented based on a study of maintenance records of 777 Japanese installations (Watanabe 1979).

Hotta (1995) presents an example of a new commercial Japanese sprinkler system, which is engineered to higher performance than conventional systems, and can be used as a subsystem of fire protection in demanding applications. Smoke detectors are used as an essential part of the system for detection fires. He discusses the key control points needed to make up a reliable system. Thomas (1998) has analysed using US data, fires in American retail premises evaluating effects of active fire protection equipment.

Observed values of failure rates from two German nuclear power plants are available from years 1988 - 1994 (Berg et al. 1997, Röwekamp et al. 1997, FKS 1997, Röwekamp & Berg 2000). The first power plant has two units of BWR available the whole 7 year periods, and the second plant has two units of PWR available for 7 and 4 (1991 - 1994) reactor years, respectively. Thus totally 21 reactor years of operational experience was available for the study. Data on the failures are given in Table 3, plant specific failure rates in Table 4, plant specific unavailabilities in Table 5, and finally comparison of unavailabilities with data from other sources in Table 6.

Table 3. Observed failures in fire detection system study of German NPPs.

| System | Population | Operational time | Function tests | Failures | |
|-------------------|------------|------------------|----------------|----------|-----------|
| | | | | crit. | non-crit. |
| | | [a] | | | |
| German BWR | | | | | |
| Alarm panels | | | | 2 | 46 |
| - plug-in units | 255 | 2627 | 13125 | 1 | |
| - detection loops | 1111 | 7783 | 38885 | 1 | |
| Fire detectors | | | | 52 | 54 |
| - automatic | 5700 | 39931 | 39900 | 50 | 38 |
| - press button | 387 | 2711 | 2709 | 2 | 16 |
| German PWR | | | | | |
| Alarm panels | | | | | |
| - plug-in units | 255 | 1786 | 7140 | | |
| - detection loops | 438 | 3068 | 1589 | | |
| Fire detectors | | | | 7 | 2 |
| - automatic | 2565 | 17969 | 17955 | 7 | |
| - press button | 227 | 1590 | 1589 | | 2 |

Table 4. Some plant specific failure rates [1/a] of fire detection and alarming systems of German NPPs.

| System | BWR | PWR1 | PWR2 |
|-------------------|------------|-------------|-------------|
| Alarm panels | | | |
| - plug-in units | 5.9E-4 | 3.0E-4 | 1.1E-2 |
| - detection loops | 2.0E-4 | 1.8E-4 | 1.4E-4 |
| Fire detectors | | | |
| - automatic | 1.2E-3 | 4.2E-4 | 3.5E-5 |
| - press button | 9.6E-4 | 3.3E-4 | 3.3E-4 |

Table 5. Some plant specific unavailabilities per demand of fire detection and alarming systems of German NPPs.

| System | BWR | PWR1 | PWR2 |
|-------------------|------------|-------------|-------------|
| Alarm panels | | | |
| - plug-in units | 1.2E-4 | 7.4E-5 | 1.1E-2 |
| - detection loops | 4.0E-5 | 4.3E-5 | 1.4E-4 |
| Fire detectors | | | |
| - automatic | 1.3E-3 | 4.2E-4 | 3.5E-5 |
| - press button | 9.4E-4 | 3.3E-4 | 3.3E-4 |

Table 6. Comparison of unavailabilities per demand of fire detection and alarming systems (Röwekamp et al. 1997).

| Study | Fire detectors |
|--|-----------------------|
| German BWR | 1.27E-3 |
| German PWR1 | 4.22E-4 |
| GAL 80 ^a | 9.00E-2 |
| GRS 85 ^b | 4.00E-3 |
| German non-nuclear industry ^c | 7.90E-2 |

a Galucci (1980) as referenced by Röwekamp et al. 1997.

b GRS (1985) as referenced by Röwekamp et al. 1997.

c Non-nuclear German data by VDS as referenced by Röwekamp et al. 1997.

4. Population and physical size of fire alarm system installations

A key question for calculating component failure rate is to know the size of the component population as a function of time during the years inspected. Since it was not known prior to our study special laborious efforts were needed to estimate it. From nuclear installations real drawings and component lists were obtained. These were used to count the number of different components, and length of cabling used. Additionally, floor areas of rooms were recorded to estimate component densities. This is needed to bind fire detection and alarming installation availability to fire frequencies, which are known per floor area (Rahikainen & Keski-Rahkonen 1998a, 1998b, Tillander & Keski-Rahkonen 2001). For non-nuclear building objects the number of installations was available, but for the population of components inside given installations only a small size of samples not randomly selected was possible to obtain. This is far from the ideal, but for explorative work we decided to be content with it. Later we return to question, whether this population size is a limiting factor for the conclusions of the study.

It was estimated a random sample of 100 buildings was needed for the studies of physical size of fire alarming installations. Addresses were drawn from the data base of SPEK. The size of the taken building was not accounted for in this drawing. The owners were contacted explaining the purpose of the study, and followed by a request for needed material. Despite repeated contacts by telephone, return from the requests was still rather small; it was supplemented by some propertyed, where better contacts were available. Still the size of the sample remained small, 44 in total.

The acquisition of this material was very time consuming. Thus we decided to go on with this sample. There are many reasons, why this goal failed, some of which we knew beforehand from related projects, like working time needed for co-operation, as well as security and confidence questions. However, the new and major problem turned out to be very wide spectrum of schooling background of contact people. Since this situation is not a problem of this project only, but a characteristic for the maintenance of fire alarming systems in general, it is worth while to pay attention to it in the beginning. It was much more difficult to explain those people the purpose and benefits, as well as real measures needed for co-operation, than e.g. in similar situations for industrial installations, where corresponding people have some kind of technical schooling. Determination of component distributions with such a small sample remained of limited value. Therefore, a new attempt to collect a larger sample of this data has already been started.

4.1 Population of fire alarm system installations

The data base of SPEK contains at least one inspection report of all fire alarm systems in operation in Finland on September 1, 1999 totalling to 11 253. In Figure 12 population of fire alarm systems in Finland as a function of installation year is plotted. If the installation year was changed due to renewing of control panel, the oldest date is retained in Figure 12. Therefore, for the early years the population curve might be somewhat inaccurate, but the last two decades are very close to real situation.

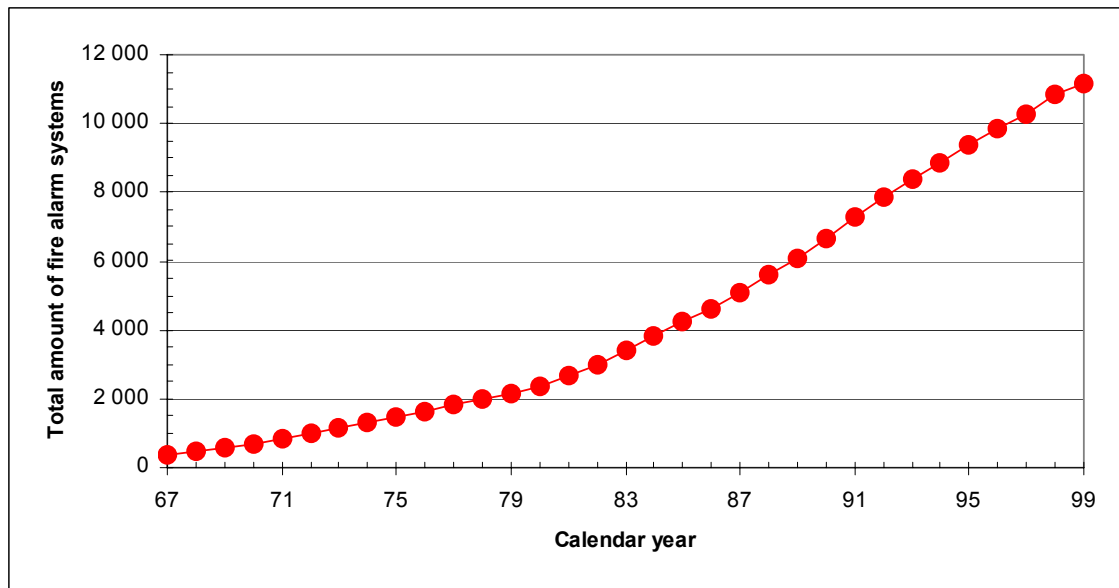

Figure 12. Population of fire alarm systems in Finland as a function of installation year.

4.1.1 Protected floor area in sampled buildings with fire alarm

Cumulative distribution of protected floor area in 44 non-nuclear buildings is plotted in Figure 13. Curve fitting by inspection using a cumulative Weibull distribution of Equation (1), where x is the floor area [m^2], yields a fair fit with parameters: $x_0 = 0 \text{ m}^2$ (two parameter Weibull distribution), $\alpha = 0.8$, and $\beta = 4\,000 \text{ m}^2$.

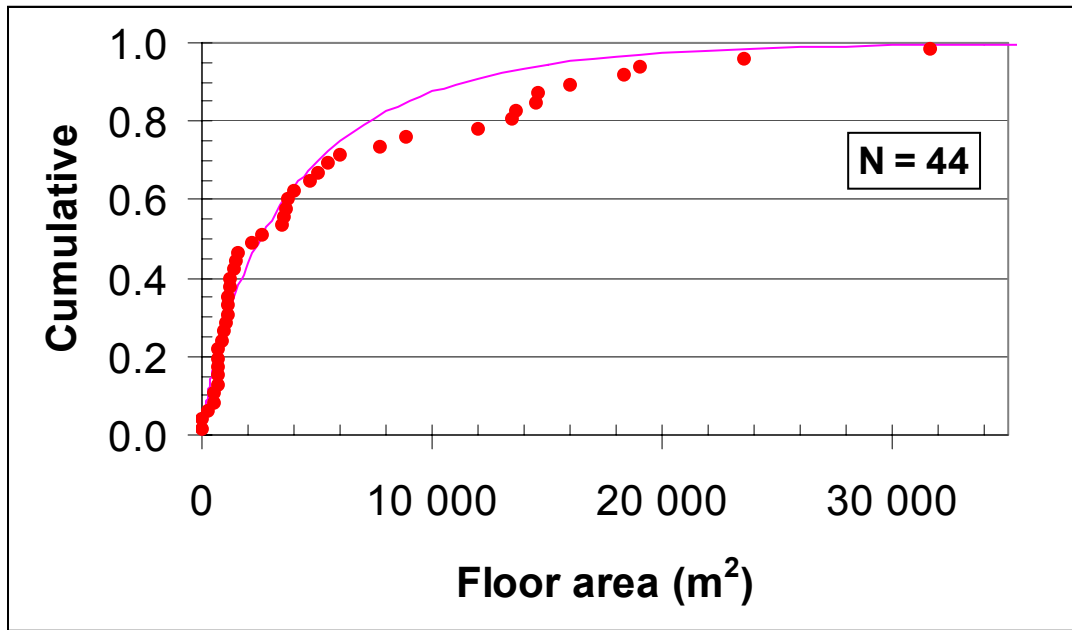

Figure 13. Cumulative distribution of protected floor areas from a sample of 44 buildings (dots) and Weibull fit (full line) on the data.

4.1.2 Fire detector density

Cumulative distribution of detector density in 18 non-nuclear buildings is plotted in Figure 14. Curve fitting using a sum of two Weibull distributions of Equation (1), where now x is the detector density [$1/m^2$], yields a good fit with parameters: $x_{01} = 0$, $x_{02} = 0.04/m^2$, $\alpha_1 = \alpha_2 = 0.8$, and $\beta_1 = \beta_2 = 0.021/m^2$. Cumulatives are 0.25 and 0.75 from distribution 1 and 2, correspondingly.

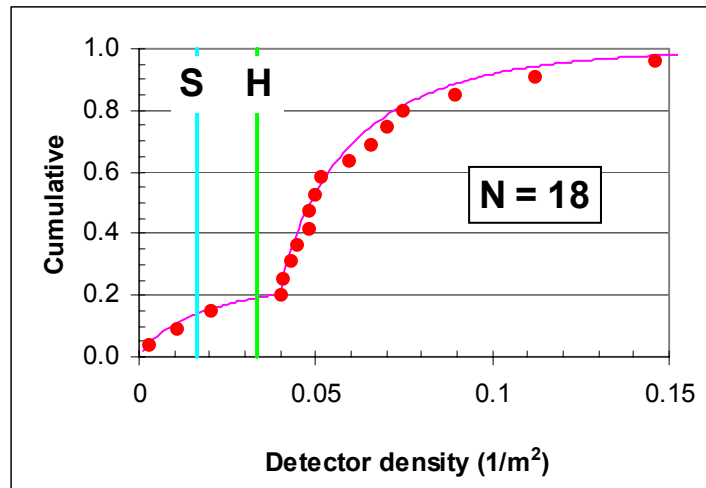

Figure 14. Cumulative density distribution of fire detectors (dots) in non-nuclear buildings, and a fit of a theoretical distribution as a sum of two Weibull distributions (full line).

4.1.3 Distribution of device circuits and detectors in non-nuclear installations

The only exact internal size information of a fire alarming installations is the number of device circuits (Nyssönen 2002). In Figure 15a the cumulative distribution of the number of circuits is plotted (bars), and a curve fit of a logarithmically normal distribution according to Equation (2) is drawn in full line with parameters: $x_0 = 0$ (two parameter lognormal distribution), $\alpha = 0.85$, and $\beta = 8.17$. Similarly the distribution of number of detectors in an installation is lognormally distributed (Figure 15b) with parameters $\alpha = 1.3$, and $\beta = 181$.

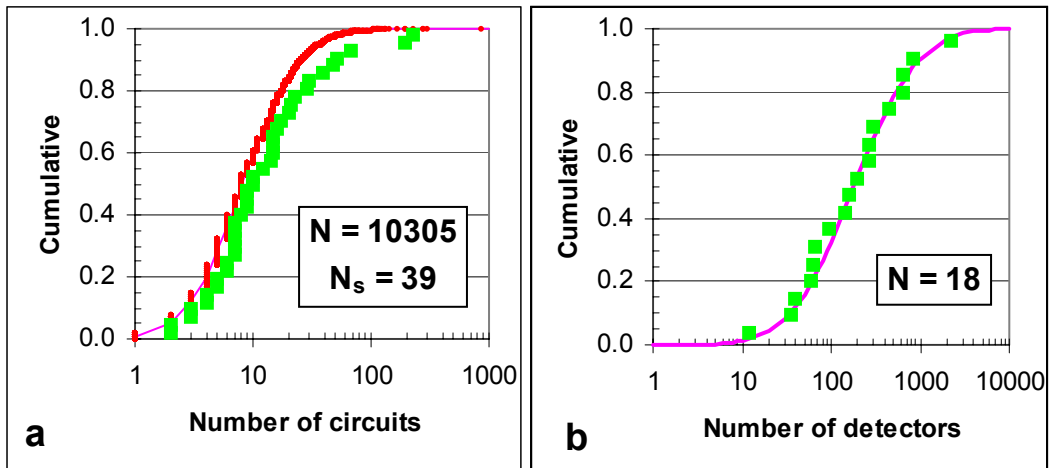

Figure 15. (a) Distribution of number of device circuits in fire alarming systems (bars) and a lognormal curve fit (full line) on the data. Distribution of circuits in sample buildings denoted by squares. (b) Distribution of number of detectors in fire alarming systems (squares) and a lognormal curve fit (full line) on the data.

According to regulations (SM A41,1991) number of circuits N_c is connected to floor area A by a relation

$$N_c = \begin{cases} 1, & A < 1600 \text{ m}^2 \\ \text{Int}(A / 1600 \text{ m}^2), & A \geq 1600 \text{ m}^2 \end{cases} \quad (11)$$

where $\text{Int}(x)$ is a function rounding a decimal number to the closest lower integer.

According to regulations (SM A41, 1991) number of smoke detectors N_d is connected to floor area A by a relation

$$N_d = \begin{cases} 1, & A < 60 \text{ m}^2 \\ \text{Int}(A / 60 \text{ m}^2), & A \geq 60 \text{ m}^2 \end{cases} \quad (12)$$

For heat detectors a similar rule applies

$$N_d = \begin{cases} 1, & A < 30 \text{ m}^2 \\ \text{Int}(A / 30 \text{ m}^2), & A \geq 30 \text{ m}^2 \end{cases} \quad (13)$$

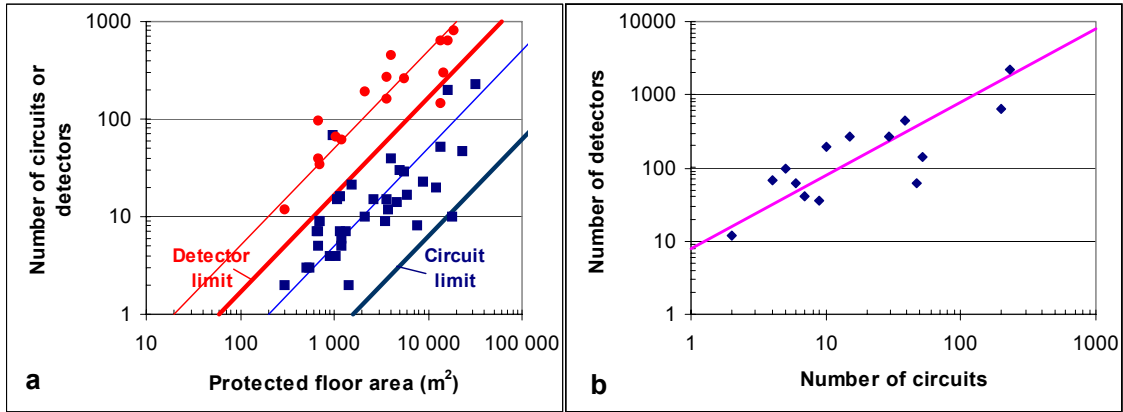

Figure 16. (a) Dependence of the number of circuits (squares) or detectors (dots) on the protected floor area. These lines indicate rough fits to observations. (b) Number of detectors as a function of the number of circuits (dots), and linear fit to data (full line).

Curve fits to observations gives a relationships on the real number of fire detectors n_d as a function of floor area

$$n_d = 1.12 (A / m^2)^{0.651} \quad (14)$$

or respectively fire circuits n_c as a function of floor area

$$n_c = 0.0654 (A / m^2)^{0.697} \quad (15)$$

Finally the number of detectors roughly as a function of circuits is given by (Figure 16b).

$$n_d = 8 n_c \quad (16)$$

Relations (14) - (16) allow estimation of the number of detectors or circuits as a function of floor area. These estimates will be used when analysing failure reports.

4.1.4 Installation age distribution in the sample of buildings

Curve fitting using a three parameter Weibull distribution of Equation (1), where now x is the age of the installation [a], yields a good fit with parameters: $x_0 = 8$ a, $\alpha = 3$, and $\beta = 9$ a as shown in Figure 16.

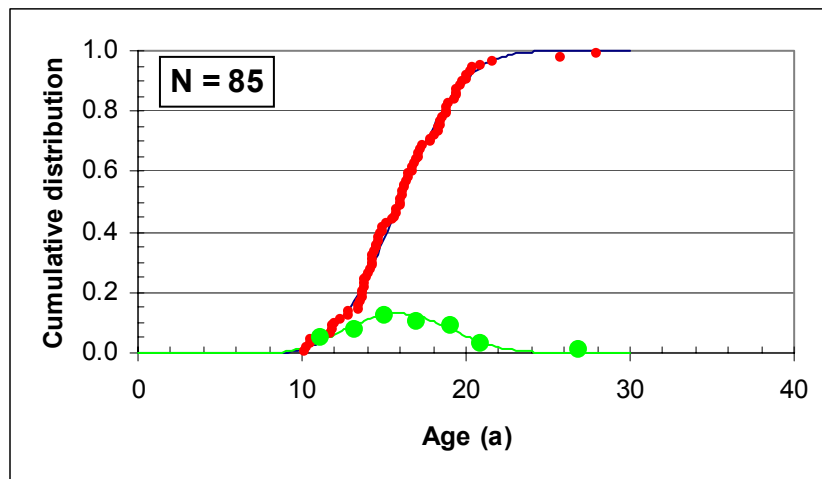

Figure 16. Distributions of the age of the installation: Observed data: cumulative distribution (small dots), density distribution (large dots); curve fits of Weibull distribution (full lines).

4.2 Fire alarms systems in NPPs

Olkiluoto OL1 reactor unit, owned by Teollisuuden Voima Oy, started operation 1978 and unit OL2 year 1980. For determination of the size and component populations of fire detection and alarm system circuit diagrams and component lists of unit OL2 were used. Circuit diagrams were updated fall 1986, and on component lists there are updates from years 1983 to 1989. Since units OL1 and OL2 are close to identical, protected floor areas were determined from the drawings of unit OL2 only. The results are presented in Appendix, Table A1.

The first installed fire detection and alarm system was a stub loop, normally open contact system as shown in Figure 1. It was divided into four local control units (sub A, B, C, and D), each of which had own power supplies. Thermal and smoke fire detectors were used; from the latter both ionisation and optical detectors were available. In early 80's optical detectors were replaced with ion detectors, because older optical detectors deteriorated quickly with age. In addition manual initiating devices were used. On each of the local panels several alarm circuits were hooked up covering all the rooms in all the buildings of the NPP units.

The old system was replaced with a new analogue, addressable system stepwise changing the area of one local panel at a time. Renovations were finished in OL1 early 2000, and the last local panel of unit OL2 was commissioned fall 2001. Partially old cables have been used. The alarm circuits has been reconfigured; the new system allows easily some additions and alterations. The new configuration of cables is a network

rather than a group of alarm loops. Therefore, after a local failure in a wire or cable, there might still be available alternative routes to communicate between the control panel and all detectors. The effects of this network is not included in the structure of fault trees in Figures 4 and 7. This is one of the details where a distributed system behaves differently from a traditional system, where each of the relevant system operated in series. In this first analysis this is left without further attention.

The number of components of the systems was counted from component lists separately for OL1 and OL2. The results are collected into Table A2. Ion detectors were changed into multi-criteria detectors consisting of ionising and optical detectors as well as of a fixed thermal limit. Also some line detectors has been installed. All the protected areas remained more or less the same as before the renovation.

Loviisa Lo1 reactor unit, owned by Fortum, started operation in February 1977 and the second unit Lo2 in November 1980. The first installed fire detection and alarm system was a normally open contact system as shown in Figure 1. Each of the reactor units had the system main control unit located in control room, and local control units spread out in various parts of the plant. There are installed detectors in all other spaces of the plant except in those, where radioactive radiation level might be considerable, like in the space containing evaporators. In such spaces triggering level of ion detectors might drift and their maintenance is difficult because of limited access. No documents were available of the installation of the original system. Therefore, the population size is not available in this paper; only the failures have been counted allowing order of magnitude comparison at a plant and unit level.

The fire detection and alarm systems in both units were changed to analogue addressable systems. In Lo1 the system was commissioned January 15, 1999 and in Lo2 November 30, 2001. All the systems were built new including cables. The new system was built on the side of the old system the area of one local control unit at a time. After finishing the installations, the new part has been tested and subsequently hooked up in the operating main control unit. The main control panel controls also fire suppression systems, fire dampers and ventilation. The installed addressable system is basically similar to the new system in Olkiluoto.

For calculating the number of components and the size of the system FSAR and implementation documents are used. Protected floor areas were calculated from the wiring layout and location diagrams of the new system. The areas were calculated separately from both units, because Lo1 and Lo2 are not identical. Furthermore the units share many common rooms, which were ascribed to one of them only. The results of counting are collected into Table A2.

4.2.1 Distribution of device circuits in NPPs

Cumulative distribution of detector density in Finnish nuclear power plants is plotted in Figure 17, and compared with of small sample on non-nuclear installations presented in Figure 12. It is seen that the distributions follow the same pattern in all cases, but detector density in NPPs is somewhat higher than in non-nuclear buildings. In gross features the distributions are Weibull distributions, but no simple theoretical distribution could be fitted closely on density distribution of NPPs, because the problem is not random enough to warrant smooth curves.

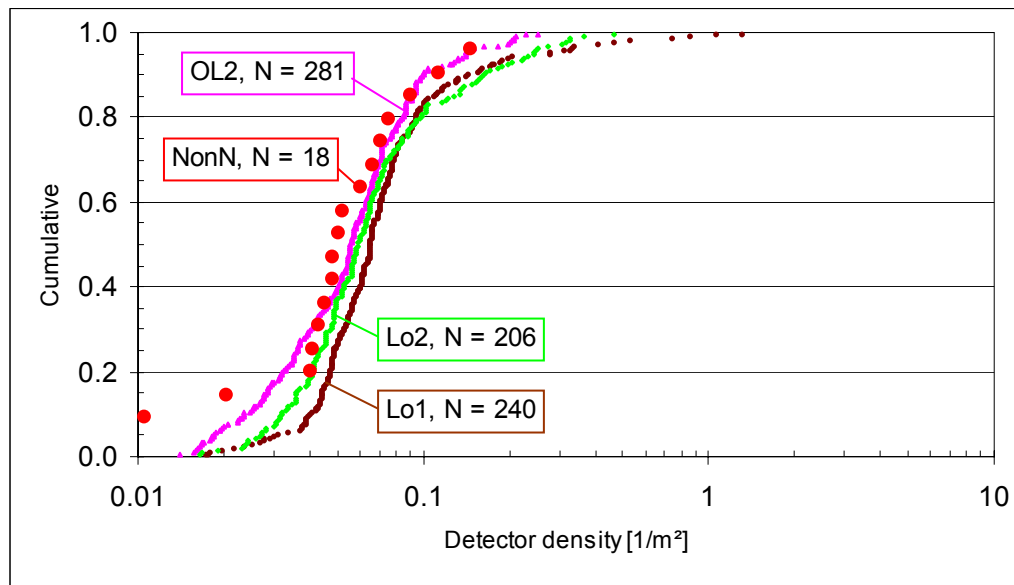

Figure 17. Detector density in Finnish nuclear installations (Lo1, Lo2, OL2) compared with a sample of non-nuclear buildings of Figure 12.

4.2.2 Distribution of cable length in NPPs

Distribution of cable length in fire detection and alarm systems was determined only from one object, Olkiluoto 2 original system selecting randomly 23 rooms and measuring cable lengths from drawings. In Figure 18a are plotted cable length [m] (squares, left scale), and cable length per floor area [m/m²] (dots, right scale) as a function of protected floor area. In Figure 18b is plotted cumulative distribution of cable length per floor area [m/m²]: observations (dots), and curve fit of a Weibull distribution (full line) with three parameters: $x_0 = 0.16$ m/m², $\alpha = 1.8$, and $\beta = 0.36$ m/m². The median value of the distribution is 0.454 m/m².

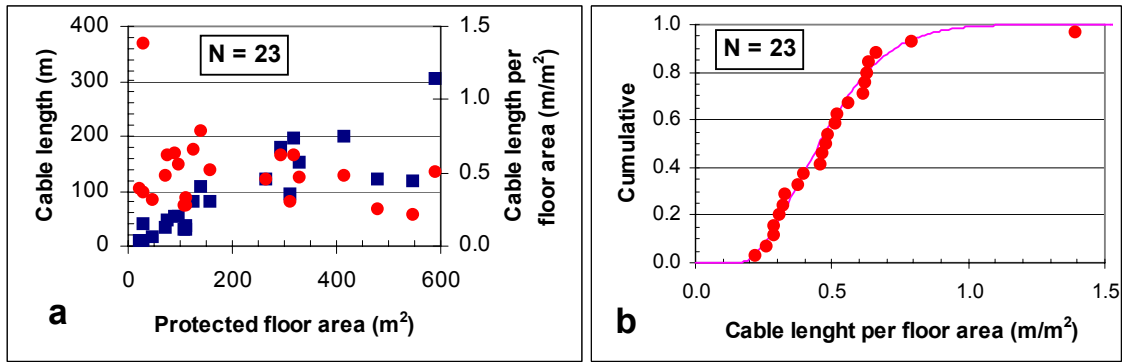

Figure 18. (a) Cable length [m] (squares, left scale), and cable length per floor area [m/m^2] (dots, right scale) as a function of protected floor area. (b) Cumulative distribution of cable length per floor area [m/m^2]: observations (dots) and curve fit of a Weibull distribution (full line).

5. Non-fire failure statistics

Studies on nuclear power plant were carried initially by Rajakko (2002) as her master's thesis. As raw data relevant maintenance reports were extracted from the data banks from all NPPs in electronic form: Lo 1 & 2 (older system): 1989 - 2001, Lo 1 (new addressable system): 1999 - 2001, OL 1 & OL 2 (older system): 1981 - 2001, and OL 1 & OL 2 (partially) (new system): 2000 - 2001. From Sweden data on Barsebäck 1 & 2: 1992 - 2000. There switch from old to new addressable system took place 1994 (unit 1) and 1996 (unit 2). This paper contains the selected major results of Rajakko's (2002) work.

Data were read on spreadsheets, sorted out in appropriate way, printed out, and inspected individually to classify observed failures. Classification was coded in additional columns of the spreadsheets, and obtained numerical data was reduced using different statistical methods.

Non-nuclear data was obtained from SPEK, which was responsible on national level of all Finnish fire detection and alarming systems during the time of this study. At the end date, September 1, 1999 their electronic data base contained 11 253 separate installations, and a total of 17 154 inspection reports. The records started 1967 initially on paper. Although these were available, we concentrated first on electronically stored data from 80's and 90's. Nyysönen (2002) analysed these data in his master's thesis. This report contains his major findings.

Since this report is probably the first Finnish scientific study on reliability of fire detection and alarming systems, no textbook-like FMEA-analysis could be carried out for several reasons. The most important of them was, that SPEK data collection form was never designed from the viewpoint of reliability studies. Therefore, this study is exploratory concentrating to presentation of obtained data, and slight discussion on their relevance and impact on reliability. Some general conclusions are made by combining data from both these raw material compilations. These results are finally to be used to build relevant system reliability models of these installations once component failure frequencies or subsystem failure frequencies and failure repair times has been extracted from statistics. How deep in detail these models can be built depends crucially on the available statistical data.

In Appendix Table A3 number of fire detection and alarm installations is given annually with number of inspections dividing them further to four categories. Figure A1 shows graphically, that the fraction of inspected installation from the total population has changed during years. Additionally, there seems to be variations in the outcome of the inspections, which are hard to derive from any type of reliability theory of the

system population. Without going any deeper, it is easy to guess, that observed variations are rather individual or intentional changes of inspection policy during years, than any changes in the collective condition of inspected fire detection and alarm system population. The positive side of this observation is, that during last ten years the ratio of inspected installations to the total population has remained rather constant.

Three categories of failure severities were used (OREDA 1992). Failure numbers in parentheses are numerical values of severity used later in respective tables.

Critical failure (1): The component does not fulfil its mission. The failure is sudden and causes cessation of one or more fundamental functions, e.g. a pump does not start, or stops, a valve does not open or close. A critical failure requires immediate corrective action in order to return the item to a satisfactory condition.

Degraded failure (2): A failure that is gradual, partial or both. It does not cease the fundamental functions but compromises one or several functions. In time such a failure may develop into a critical failure, and therefore corrective actions should be taken as soon as possible. Small leakage, wear and natural ageing are examples of such failures.

Incipient failure (3): An imperfection in the state or condition of an item so that a degraded or critical failure can be expected to result if corrective action is not taken. Corrective action can be postponed to a suitable time. Incipient failures do not essentially increase unavailability. Corrosion failures are an example of incipient failures in sprinkler installations.

One of the classification criteria has been the failure detection. The most common failure detection has been a system failure report to control room. For addressable system there are four types of alarm reports: service, fault, fire, and prewarning of fire. In the old normally open system only two alarm reports are available: open or short alarm circuit; other alarms are fires.

During periodic testing and inspections as well as other maintenance failures are observed, which the system does not report. They seldom impair the system operation. Many of the failures influence system only very locally. Failure of a detector or a manual initiating device does not influence other parts of the system. In addressable system a faulty component is found easily due to discrete addresses. A short in an alarm circuit invalidates the circuit only between two closest short circuit isolators or the rest of the circuit until the end-of-line resistor. Other parts of the alarm circuit operate normally. Failure in a local alarm control unit influences only the area controlled by that subunit. Failures in graphic displays or user interphase do not make system control units or auxiliary system control units inoperable.

In the old normally open system failure of an indicator bulb does not cause a fault or service alarm. The failure is observed only in testing or inspection. Alarms due to sprinkler operation leading to service of a detector are classified to (6) false alarms, because sprinklers are here manually controlled.

Fire detection and alarm system gives false or erroneous unwanted alarms due to changed environment (temperature, humidity, water, smoke, dust, and vapour). Mechanical damage, strong air flow/ventilation and bad contacts due to oxidising agents release (false) fire alarms as a consequence of failures in components. Failure alarms result from failures in alarm circuits, system control unit, UPS, and communication unit. No failure alarms are caused by defect indicator bulbs in system control unit, failed auxiliary system control relays, and unlocked door of the system control unit.

OREDA (1992) classification categories were further interpreted in this work to take partially into account viewpoint (i) described under 2.2 to get the first guess on total effect of failures to the system. The modified classification rules become:

Critical failure (1): Critical failure is a component failure influencing negatively on the operation or reliability of the whole system. Because fire detection and alarming system is partly parallel in the sense of reliability, there are only a few critical failures. One group critical failures are those invalidating whole alarming circuits or all the addresses of a local control unit. A critical failure was a failure of announcement forwarding to control room or fire department.

Degraded failure (2): All cases, where addressable system reports detector failures into control room. The faulty detector is out, but there are other detectors in the same room, from which an alarm is obtained. False alarm or prewarning of fire is recorded here, if the detector was found defect, or the reason of alarm was not found.

Incipient failure (3): A group of these failures is service reports to control room from addressable system like (1.1) 'dirty detector'. Detector has become less sensitive but is not totally out. If more than half of the detectors in the room are simultaneously faulty, the classification is category 2 because of negative influence on the whole system. It contains false alarms, and fire prewarnings, during which the system is in operation. Power supply failures, if not influencing function of batteries, defect indicator lamp bulbs, if they have not caused an alarm, and failures in the testing system belong to this category. In the old normally open contact system 'open alarm circuit' belongs to communication error. It is category 2, if disconnection is needed, otherwise category 3.

The weakness of this approach is, that no strictly quantitative evaluation of the system is obtained, as could be gained by carrying out analysis in the sense of viewpoint (ii),

and then returning to the performance of the complicated distributed system. The motivation, however, is to gain quickly an order of magnitude estimate of the system from the viewpoint (i). From the results obtained here, it is rather easy to pick up failures of detectors, and part of failures is communications for modification of fault trees given in Figures 4, 5 and 7 to take into account in a proper way, that several detectors and communication lines might be available more or less parallel. This is the task of later investigations.

Number of failures is classified also according to detection mode, shown for clarity in a tree of Figure 19. The modes and their short hand descriptions are: testing (Test), inspection (Insp), operation (Use), alarm (Alarm), trouble alarm (Trouble a), fire alarm (Fire a), and mode not mentioned (Ukn).

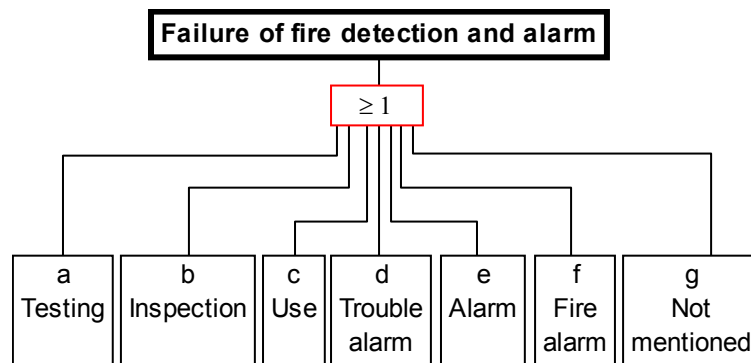

Figure 19. Fault tree of failure detection modes of fire detection and alarm installations.

5.1 Non-nuclear installations in Finland

Failures observed from non-nuclear installations in Finland are described, and classified. All the separate (59) failure descriptions were listed with the number of inspections, where it was observed. In one inspection several failures of the same types were found. Maximum number in a single inspection for a failure group is also given just for curiosity together with the total number of failures observed in all inspections including that failure group. Finally failure severity category number is given, and an address of the failure group in the fault trees is assigned. This intermediate table was worked out to smaller groups classified according to failure severity (Tables 7 - 9). Failures are grouped together to boxes of the fault trees. Evaluation of failures per demand in the boxes of fault trees down to level two are given in Table 7 for critical (1), Table 8 for degraded (2) and Table 9 for incipient (3) failures. The main criterion has been viewpoint (ii) influencing determination of failure severity classification. Thus in the

areas where parallel systems exist (like detectors), a single failure is not considered critical from the point of view of the system, item (i).

Table 7. Number of critical (1) failures, and point estimates of failures per demand in non-nuclear fire detection and alarm installations in Finland.

| Failure group and type in fault tree | Number | Latent failures per demand | | |
|---|--------|----------------------------|--------|--------|
| | | min | point | max |
| Critical failure in control unit (2) | 22 | 9.4E-4 | 1.3E-3 | 1.8E-3 |
| Faulty initiating circuit (3.2) | 188 | 8.3E-4 | 9.4E-4 | 1.1E-3 |
| Initiating circuit signaling fault (3.2) | 110 | 4.7E-4 | 5.5E-4 | 6.4E-4 |
| Failure in announcement forwarding (3.3) | 48 | 2.2E-3 | 2.8E-3 | 3.6E-3 |
| Announcement forwarding not connected (3.3) | 187 | 9.7E-3 | 1.1E-2 | 1.2E-2 |
| Initiating circuit disconnected (3.4) | 118 | 5.1E-4 | 5.9E-4 | 6.8E-4 |

In Table 10 failure groups from the original classification presented in Tables 7 to 9 belonging to same branches of 'fault trees' has been summed up to give a general view of failure occurrence. By carrying out this needs for modifications of 'fault trees' (Figures 4 - 10) became apparent. However, here nothing has been changed compared to early versions, but they are left to later studies, when more detailed modelling has been carried out, and real fault trees based on statistics has been set up.

Table 8. Number of degraded (2) failures and point estimates of failure frequencies in non-nuclear fire detection and alarm installations in Finland.

| Failure group and type in fault tree | Number | Latent failures per demand | | |
|---|--------|----------------------------|------------------|------------------|
| | | min | point | max |
| Detector missing (1.1) | 8461 | 1.1E-3 | 1.2E-3 | 1.2E-3 |
| Detector covered (1.1) | 126 | 1.5E-5 | 1.7E-5 | 2.0E-5 |
| Faulty detector (1.2) | 747 | 9.7E-5 | 1.0E-4 | 1.1E-4 |
| Improper detector to control unit or current location (1.2) | 80 | 9.3E-6 | 1.1E-5 | 1.3E-5 |
| Detector mounted in insulating material (1.2) | 491 | 6.3E-5 | 6.8E-5 | 7.3E-5 |
| Detector not approved to control unit (1.2) | 131 | 1.6E-5 | 1.8E-5 | 2.1E-5 |
| No fault alarm from detector (1.2) | 68 | 2.8E-4 | 3.4E-4 | 4.1E-4 |
| Detector signaling failure (1.2) | 22 | 9.4E-4 | 1.3E-3 | 1.8E-3 |
| Incorrect detector in initiating circuit (1.2) | 69 | 2.8E-4 | 3.4E-4 | 4.2E-4 |
| Faulty manual initiating device (2.3) ^a | 225 | 1.0E-3 1.2E-2 | 1.1E-3 1.3E-2 | 1.2E-3 1.5E-2 |
| Detector disconnected (3.2) | 96 | 1.1E-5 | 1.3E-5 | 1.6E-5 |
| No fault alarm from initiating circuit (3.2) | 59 | 2.4E-4 | 2.9E-4 | 3.6E-4 |
| Failure in fault alarm annoucement forwarding (3.3) | 81 | 3.4E-4 | 4.0E-4 | 4.8E-4 |
| Ground short (3.5) | 110 | 5.5E-3 | 6.4E-3 | 7.5E-3 |
| Fault in standby batteries (5.1) | 332 | 1.8E-2 | 1.9E-2 | 2.1E-2 |
| Annoucement forwarding not connected to standby batteries (6.2) | 14 | 5.6E-4 | 8.2E-4 | 1.3E-3 |

a) Number of devices not known, but estimated to number of loops (upper figures) or to number of installations (lower figures).

Table 9. Number (N) of incipient (3) failures and point estimates of failure frequencies in non-nuclear fire detection and alarm installations in Finland.

| Failure group and type in fault tree | N | Latent failures per demand | | |
|---|------|----------------------------|------------------|------------------|
| | | min | point | max |
| Detector hidden (1.1) | 28 | 2.9E-6 | 3.9E-6 | 5.3E-6 |
| Detector not cleaned (1.1) | 330 | 4.2E-5 | 4.6E-5 | 5.0E-5 |
| Detector installed in incorrect place (1.1) | 777 | 1.0E-4 | 1.1E-4 | 1.1E-4 |
| Detector too close to a false alarm source (1.1) | 62 | 7.0E-6 | 8.6E-6 | 1.1E-5 |
| Detector's shield missing (1.1) | 95 | 1.1E-5 | 1.3E-5 | 1.6E-5 |
| Detector's indicator light failure (1.2) | 279 | 3.5E-5 | 3.9E-5 | 4.3E-5 |
| Detector in wrong position (1.2) | 70 | 8.0E-6 | 9.7E-6 | 1.2E-5 |
| More sensitive detector recommended (1.2) | 2880 | 3.9E-4 | 4.0E-4 | 4.1E-4 |
| Less sensitive detector recommended (1.2) | 2741 | 3.7E-4 | 3.8E-4 | 3.9E-4 |
| Detector not mounted properly (1.2) | 420 | 5.4E-5 | 5.8E-5 | 6.3E-5 |
| Detector obsolete (1.2) | 21 | 2.1E-6 | 2.9E-6 | 4.2E-6 |
| Detector not needed (1.2) | 144 | 1.7E-5 | 2.0E-5 | 2.3E-5 |
| Other detector deficiency (1.2) | 224 | 2.8E-5 | 3.1E-5 | 3.5E-5 |
| Other control unit deficiency (2) | 1080 | 6.0E-2 | 6.3E-2 | 6.6E-2 |
| Deficiency in manual initiating device (2.3) ^a | 403 | 1.8E-3 2.2E-2 | 2.0E-3 2.3E-2 | 2.2E-3 2.5E-2 |
| Crosswired (3.1) | 121 | 6.1E-3 | 7.1E-3 | 8.2E-3 |
| Detector connected to wrong circuit/group (3.1) | 729 | 4.0E-2 | 4.2E-2 | 4.5E-2 |
| Short circuit device missing (3.1) | 20 | 8.4E-4 | 1.2E-3 | 1.7E-3 |
| Incorrect cable (3.1) | 66 | 3.2E-3 | 3.8E-3 | 4.7E-3 |
| Other deficiency in cables (3.1) | 115 | 5.8E-3 | 6.7E-3 | 7.8E-3 |
| No control unit grounding (3.5) | 157 | 8.1E-3 | 9.2E-3 | 1.0E-2 |
| Failure in alarm device (4) | 832 | 4.6E-2 | 4.9E-2 | 5.1E-2 |
| Failure in auxiliary control subsystems (4.2) | 78 | 3.8E-3 | 4.5E-3 | 5.5E-3 |
| Charger fault (5.1) | 24 | 1.0E-3 | 1.4E-3 | 2.0E-3 |
| New standby batteries recommended (5.2) | 104 | 5.2E-3 | 6.1E-3 | 7.1E-3 |
| Other fault in standby batteries (5.3) | 88 | 4.3E-3 | 5.1E-3 | 6.1E-3 |
| Failures of previous inspection not repaired (6.1) | 176 | 9.1E-3 | 1.0E-2 | 1.2E-2 |
| Not approved installation company (6.1) | 15 | 6.0E-4 | 8.7E-4 | 1.3E-3 |
| Alarm log missing (6.2) | 192 | 1.0E-2 | 1.1E-2 | 1.3E-2 |
| Monthly testing neglected (6.2) | 391 | 2.1E-2 | 2.3E-2 | 2.5E-2 |
| Maps not updated (6.2) | 4125 | 2.4E-1 | 2.4E-1 | 2.5E-1 |
| Part of maps missing (6.2) | 90 | 4.5E-3 | 5.2E-3 | 6.2E-3 |
| No maps (6.2) | 44 | 2.0E-3 | 2.6E-3 | 3.3E-3 |
| Other map deficiency (6.2) | 399 | 2.1E-2 | 2.3E-2 | 2.5E-2 |

a) Number of devices not known, but estimated to number of loops (upper figures) or to number of installations (lower figures).

Table 10. Summary of failures severity groups and fault types. Point estimates of failures per demand in non-nuclear fire detection and alarm installations in Finland.

| Failure group and type in fault tree | Fault type | Latent failures per demand | | |
|--|------------|----------------------------|--------|--------|
| | | min | point | max |
| Failure severity 1 | | | | |
| Critical failure in control unit | 2 | 9.4E-4 | 1.3E-3 | 1.8E-3 |
| Failure in initiating circuit | 3.2 | 1.4E-3 | 1.5E-3 | 1.6E-3 |
| Failure in announcement forwarding | 3.3 | 1.2E-2 | 1.4E-2 | 1.5E-2 |
| Initiating circuit disconnected | 3.4 | 5.1E-4 | 5.9E-4 | 6.8E-4 |
| Failure severity 2 | | | | |
| Detector dirty | 1.1 | 1.2E-3 | 1.2E-3 | 1.2E-3 |
| Detector faulty | 1.2 | 2.1E-4 | 2.2E-4 | 2.3E-4 |
| Faulty manual initiating device ^a | 2.3 | 1.0E-3 | 1.1E-3 | 1.2E-3 |
| | | 1.2E-2 | 1.3E-2 | 1.5E-2 |
| Detector disconnected | 3.2 | 1.1E-5 | 1.3E-5 | 1.6E-5 |
| No fault alarm from initiating circuit | 3.2 | 2.4E-4 | 2.9E-4 | 3.6E-4 |
| Failure in fault alarm announcement forwarding | 3.3 | 3.4E-4 | 4.0E-4 | 4.8E-4 |
| Ground short | 3.5 | 5.5E-3 | 6.4E-3 | 7.5E-3 |
| Fault in standby batteries | 5.1 | 1.8E-2 | 1.9E-2 | 2.1E-2 |
| Announcement forwarding not connected to standby batteries | 6.2 | 5.6E-4 | 8.2E-4 | 1.3E-3 |
| Failure severity 3 | | | | |
| Detector dirty | 1.1 | 1.7E-4 | 1.8E-4 | 1.9E-4 |
| Detector faulty | 1.2 | 9.2E-4 | 9.4E-4 | 9.6E-4 |
| Other control unit deficiency | 2 | 6.0E-2 | 6.3E-2 | 6.6E-2 |
| Deficiency in manual initiating device ^a | 2.3 | 1.8E-3 | 2.0E-3 | 2.2E-3 |
| | | 2.2E-2 | 2.3E-2 | 2.5E-2 |
| Wire/cable failure | 3.1 | 5.8E-2 | 6.1E-2 | 6.4E-2 |
| No control unit grounding | 3.5 | 8.1E-3 | 9.2E-3 | 1.0E-2 |
| Failure in alarm device | 4 | 4.6E-2 | 4.9E-2 | 5.1E-2 |
| Failure in auxiliary control subsystems | 4.2 | 3.8E-3 | 4.5E-3 | 5.5E-3 |
| Charger fault | 5.1 | 1.0E-3 | 1.4E-3 | 2.0E-3 |
| New standby batteries recommended | 5.2 | 5.2E-3 | 6.1E-3 | 7.1E-3 |
| Other fault in standby batteries | 5.3 | 4.3E-3 | 5.1E-3 | 6.1E-3 |
| Human error | 6.1 | 9.9E-3 | 1.1E-2 | 1.3E-2 |
| Instruction error | 6.2 | 3.2E-1 | 3.3E-1 | 3.3E-1 |

a) Number of devices not known, but estimated to number of loops (upper figures) or to number of installations (lower figures).

5.2 Non-fire failures in nuclear power plants

5.2.1 Number of failures by categories and plants

In Table 11 an overview of number of failures of fire detection and alarm systems is presented in various nuclear power plants divided into subgroups according to Figure 4. Division is also made by the system: original alarm circuits, and new addressable systems. The last division is by the severity of failure in three classes as explained above. In Appendix, Tables A4 to A9 detailed lists of failures are given down to the third level as indicated in fault trees of Figures 5 to 10. It is seen already from summary Table 10, that in many categories there are only a few observed failures. Therefore, it must be decided by further analyses once real failure frequencies become available, when and for what purposes a further division beyond Figure 4 is useful.

Some quick qualitative comments on the collected data are made for clarification of possible questions. Failure of detector is the most frequent failure. According to Table 11 there were only few detector failures of Loviisa original system as compared with other NPPs. The reason might be, that some of these has been classified as communication failures. Here it was interpreted the failure be a communication failure, if a circuit alarmed, but no reason was given for the alarm. It is possible, that the real reason was a faulty detector.

Table 11. Number of observed failures of fire detection and alarm systems in various NPPs divided into subsystems according to Figure 4, original and new systems, as well as three severity classes.

| NPP | System | Severity | Failures in fire detection and alarm subsystems | | | | | | |
|--------------------|--------|----------|---|------------|------------|-----------|-----------|-----------|-------------|
| | | | Det | Comp | Comm | Control | PS | False | Total |
| Ol | or | 1 | | 1 | 1 | | | | 2 |
| | | 2 | 268 | 45 | 73 | 6 | 3 | | 395 |
| | | 3 | 10 | 31 | 16 | 1 | 12 | 7 | 77 |
| | | Total | 278 | 77 | 90 | 7 | 15 | 7 | 474 |
| | adr | 1 | 1 | 1 | | | | | 2 |
| | | 2 | 19 | 4 | 10 | | | | 33 |
| | | 3 | 27 | 6 | 4 | | 2 | 3 | 42 |
| | | Total | 47 | 11 | 14 | | 2 | 3 | 77 |
| Lo | or | 1 | | 2 | | | | | 2 |
| | | 2 | 169 | 105 | 151 | 3 | 11 | 5 | 444 |
| | | 3 | 8 | 73 | 38 | 4 | 8 | 23 | 154 |
| | | Total | 177 | 180 | 189 | 7 | 19 | 28 | 600 |
| | adr | 1 | | | 1 | | | | 1 |
| | | 2 | 6 | 4 | 6 | 5 | 4 | | 25 |
| | | 3 | | 3 | 2 | | 2 | | 7 |
| | | Total | 6 | 7 | 9 | 5 | 6 | | 33 |
| Ba | or | 1 | | | | | | | |
| | | 2 | 37 | 11 | 4 | | 1 | | 53 |
| | | 3 | | | | | | | |
| | | Total | 37 | 11 | 4 | | 1 | | 53 |
| | adr | 1 | | 1 | | | | | 1 |
| | | 2 | 104 | 11 | 16 | 5 | 3 | | 139 |
| | | 3 | 1 | 2 | 2 | 1 | 2 | | 8 |
| | | Total | 105 | 14 | 18 | 6 | 5 | | 148 |
| Total | or | | 492 | 268 | 283 | 14 | 35 | 35 | 1127 |
| | adr | | 158 | 32 | 41 | 11 | 13 | 3 | 258 |
| Grand total | | | 650 | 300 | 324 | 25 | 48 | 38 | 1385 |

OL = Olkiluoto, Lo = Loviisa, Ba = Barsebäck, or = original system, adr = new addressable system

In Loviisa the whole installation was renovated using new components only. In Olkiluoto old cabling has been used where feasible. In Barsebäck the largest group of failures was 'invalid sensor response'. The reason might be either a soiled detector or an impaired detector due to high radiation level in the respective space. Fire detection and alarming system in Barsebäck has been tuned to indicate trouble or unwanted alarm, if the sensor response is a factor 2 to 3 below the default value, which is a considerable decrease of sensitivity of the system. No detailed information was available on the time of commissioning of the new addressable system in Barsebäck.

5.2.2 Details on critical failures

Less than 1% of the failures was classified to severity class 1, critical failures, which has a direct influence on the function of the system performance. Totally 8 such failures was found from the material of all NPPs studied and shown in the fault tree of Figure 20. A critical failure needs compensating fire protection measures during down time like fire watch on the zone influenced. Although rather different systems were combined into Figure 20, it emphasises more than detailed data in Table 10, that system component and subsystem communication failures are the most common of the critical failures. About 80% of the failures were class 2, which influences only on the failed component or subsystem. Class 3 included some 20% of failures, which do not prevent any functions at the time of detection.

For clarification of the details of these critical failures, each of them is described individually in a few sentences. In the beginning of description is an alphanumerical code, which places the failure in fault trees of Figures 20 and 21.

At Barsebäck one critical failure was observed indicated in the following boxes of fault trees: Figure 20: 2.2.(1), and Figure 21: (f). It was detected as a result of unwanted fire alarm; none of three detectors indicated smoke, still an alarm was released, and ventilation was stopped. No manual reset was possible from control panel, which turned out to be faulty. The control panel was replaced and detectors tested. The failure of the control panel disconnected all the zone to control room. Down time was 12 h, of which 11 h waiting, and 1 h repair.

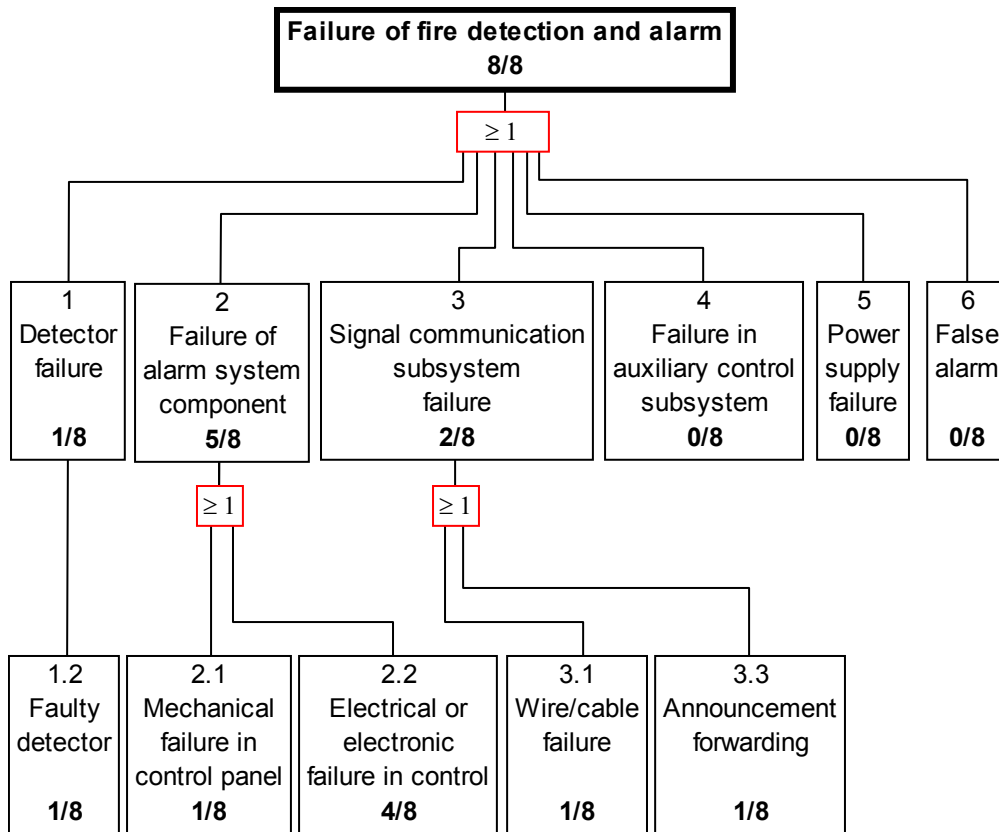

Figure 20. Distribution of 8 severity class 1 or critical failures on the fault tree of fire detection and alarming systems in NPPs.

At Loviisa three critical failures were detected, two in the original system and one in the new addressable system. The first failure of the original system is in boxes: Figure 20: 2.2(2) , Figure 21: (c). Announcement forwarding failed to guards and plant fire department because transmitting was blocked by a blown fuse in the control unit. It was neither observed in testing nor caused a trouble report, but revealed accidentally. Total down time was 70 h.

The second critical failure of the original system in Loviisa is in boxes: Figure 20: 2.1(1) , Figure 21: (b). Failure of cabinet door switch of a local control unit, which prevented resetting of 'door open' alarm. 'Door open' prevents announcement forwarding of a possible alarm to control room and plant fire department. Down time was 67 h. There were totally 33 door switch failures in the material studied, but in all other cases 'door open' alarm could be reset by closing cabinet door provisionally by some means until repair. Failures of cabinet door switch and door lock are due to natural wear and ageing. The failures are usually found in inspections, because of blocked announcement forwarding.

The only critical failure of the new addressable system in Loviisa is in boxes: Figure 20: 3.3(1) , Figure 21: (e). It was a communication failure between the main and local

control unit. Detectors from several circuits gave unwanted fire alarms, which could not be reset. The reason of the failure was a defect modem unit, which was replaced. Down time of the influenced zone was 37 h.

In Olkiluoto totally four critical failures were found, two of each generation of systems. In the old system the reason of the first failure was a cable damaged during renovation work. It is indicated in boxes: Figure 20: 3.1(1), Figure 21: (d). Connection to whole loop was lost until it was replaced with a new one. Down time was 49 h, 25 h waiting and 24 h repair.

The second critical failure in Olkiluoto old system is indicated in boxes: Figure 20: 2.2(4), Figure 21: (d). The reason of the failure was a faulty circuit card, which influences on all connected circuits and detectors. In the material there were totally 10 circuit card failures. One of them is classified critical, because the reason of the failure was not known. Down time was 2 h, 1 h for waiting, 1 h for repair.

The first critical failure in addressable system in Olkiluoto is indicated in boxes: Figure 20: 1.2(1), Figure 21: (d). Several detectors reported trouble, and they were disconnected from the circuit. Later it turned out, that several of them belonged to a faulty series, where detector code had an error driving the detector to a permanent trouble state. Detectors were reprogrammed, and if not functioning properly changed to new ones during periodic outage. The failure was deemed critical, because change of detectors was postponed until the next outage, which meant for some of them almost a year of permanent trouble state. Therefore, the fire detector installation was partially down for 7949 h or approximately 11 months.

The second critical failure in addressable system in Olkiluoto is indicated in boxes: Figure 20: 2.2(4), Figure 21: (d). The failure was caused by a defect memory chip in a local control unit. Communication between the main and local control units was interrupted for 23 h, waiting for 20 h and for repair 3 h. The chip was changed and reprogrammed.

Number of failures is classified in Table 12 according to detection mode, plant and system. The detection modes have been coded in majority of the reports or has been described in connection of the cause of the failure. The short hand descriptions of detection modes are: testing (Test), inspection (Insp), operation (Use), alarm (Alarm), false alarm (False a), fire alarm (Fire a), and mode not mentioned (Ukn).

Table 12. Number of failures according to detection mode.

| NPP | System | Detection mode of failures | | | | | | | Total |
|--------------------|--------|----------------------------|-----------|------------|-----------|------------|------------|----------|-------------|
| | | Test | Insp | Use | Alarm | False a | Fire a | Ukn | |
| Olki- luoto | Orig. | 76 | 6 | 7 | 6 | 139 | 233 | 7 | 474 |
| | Addr. | 2 | | | | 63 | 12 | | 77 |
| Loviisa | Orig. | 135 | 58 | 83 | 33 | 154 | 137 | | 600 |
| | Addr. | 2 | 1 | 11 | 6 | 9 | 4 | | 33 |
| Barse- bäck | Orig. | 1 | 1 | 4 | | 18 | 28 | 1 | 53 |
| | Addr. | 4 | 3 | 13 | | 101 | 27 | | 148 |
| Total | Orig. | 212 | 65 | 94 | 39 | 311 | 398 | 8 | 1127 |
| | Addr. | 8 | 4 | 24 | 6 | 173 | 43 | | 258 |
| Grand total | | 220 | 69 | 118 | 45 | 484 | 441 | 8 | 1385 |

In Figure 21 severity 1 or critical failures are represented graphically on a fault tree pooling all treated NPPs together.

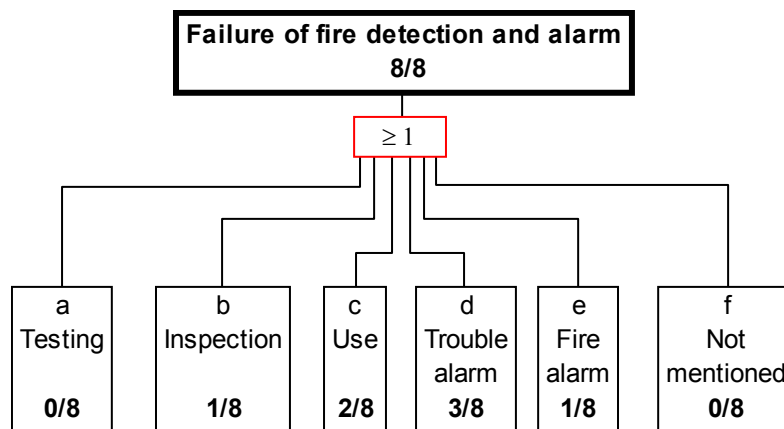

Figure 21. Detection mode distribution of 8 severity class 1 or critical failures.

For the new addressable systems the relative amount of fire alarms has dropped markedly while trouble alarms have increased. In the old systems majority of 'fire alarms' were unwanted alarms due to soiled or defect detectors. The development is in towards positive direction, and the new systems have become trustworthier in the eyes of the relevant personnel.

5.3 Inspection time interval distribution

In Figure 22 inspection time intervals [a] are plotted from SPEK data individually for years 1996 – 1999 as cumulative distributions (left), and as relative frequency distribution for the whole period (right). The goal for periodic inspection intervals has been 5 ... 6 a, which explained fairly well the sharp peak found on the right plot (peak at 6.3 a). Renewal inspections shortly after the main inspection again explain high amount of inspections for intervals less than 1 a ($0.11 \text{ a} = 1.3 \text{ months}$). Furthermore, the shape of the distributions is roughly logarithmically normal as indicated on the logarithmical time scale right. The cumulative distribution left is roughly a sum of these two distributions, but no quantitative fit is made here.

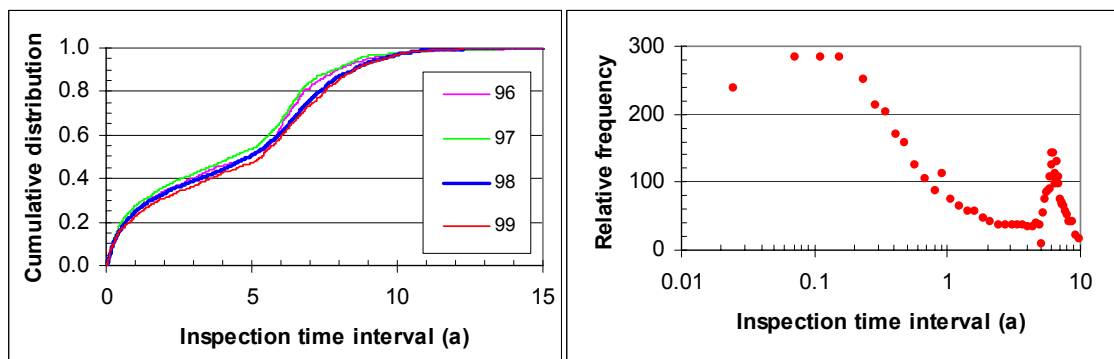

Figure 22. Distribution of inspection time intervals. Left: Cumulative distribution annually 1996 - 1999. Right: Combined distribution density function is roughly a sum of two logarithmically normal distributions centred at 0.11 a (1.3 months) and 6.3 a.

6. Estimation of component failure rates

Some preliminary point estimate failure rates are given below for a selected group of components. No deeper analysis or calculation of error limits is made, because initial populations and collection periods were not so very well available. The use of these values is to look on the order of magnitudes, which would be helpful in later analysis of the fire detection and alarm system performance. The failures of the components of the signalling systems were classified into three categories.

Table 13. Observation periods of failures of fire detection and alarming systems in various NPPs (two different times still to be checked).

| NPP | System | Period | Time [a] | |
|-------------|-----------|-------------------------------|----------|-------|
| | | | | |
| Loviisa 1 | Original | Febr 1, 1989 - Nov 20, 2001 | 12.83 | 12.84 |
| | New addr. | Jan 15, 1999 - Feb 6, 2002 | 2.02 | 3.06 |
| Loviisa 2 | Original | Febr 1, 1989 - Nov 20, 2001 | 12.83 | 12.84 |
| | New addr. | Jan 15, 1999 - Feb 6, 2002 | 2.02 | 3.06 |
| Olkiluoto 1 | Original | Nov 1, 1981 - Dec 31, 2000 | 20.00 | 19.18 |
| | New addr. | Dec 1, 2000 - Dec 31, 2001 | 1.08 | 1.08 |
| Olkiluoto 2 | Original | Nov 1, 1981 - Dec 31, 2000 | 20.00 | 19.18 |
| | New addr. | Dec 1, 2000 - Dec 31, 2001 | 1.08 | 1.08 |
| Barsebäck 1 | Original | March 1, 1992 - Sept 30, 1995 | 3.58 | 3.58 |
| | New addr. | July 1, 1994 - Sept 15, 2000 | 6.25 | 6.30 |
| Barsebäck 2 | Original | March 1, 1992 - Sept 30, 1995 | 3.58 | 3.58 |
| | New addr. | July 1, 1994 - Sept 15, 2000 | 6.25 | 6.30 |

6.1 Failures of fire alarm heads

In Table 14 preliminary point estimates of failure frequencies $[1/a]$ of fire alarm heads are presented for Finnish NPPs. In this first round all different types of detectors were pooled together, although there was accurate information of various types in the new addressable systems.

Table 14. Point estimates of failure frequency [1/a] of fire alarm heads in Finnish NPPs.

| NPP | System | Severity | Population | Time [a] | Failures | Failure frequency [1/a] |
|-----------|-----------|----------|------------|----------|----------|-------------------------|
| Loviisa | Original | 1 | 3673 | 12.83 | 0 | |
| | | 2 | | | 169 | 3.6E-3 |
| | | 3 | | | 177 | 3.8E-3 |
| | New addr. | 1 | 3673 | 2.08 | 0 | |
| | | 2 | | | 6 | 7.9E-4 |
| | | 3 | | | 0 | |
| Olkiluoto | Original | 1 | 4598 | 20 | 0 | |
| | | 2 | | | 268 | 2.9E-3 |
| | | 3 | | | 10 | 1.1E-4 |
| | New addr. | 1 | 4798 | 1.08 | 1 | 1.9E-4 |
| | | 2 | | | 19 | 3.7E-3 |
| | | 3 | | | 27 | 5.2E-3 |

6.2 Failures of cables

For estimation of failure frequency of cables only the new systems in Loviisa and Olkiluoto were available. It was assumed that the amount of cables was approximately the same in the original systems. In Table 15 preliminary point estimates of the failure frequency per length [1/am] is given without calculating error ranges.

Table 15. Point estimates of failure frequency per length [1/am] of cables of fire detection and alarm installations in Finnish NPPs.

| NPP | System | Population [m] | Time [a] | Failures | Failure frequency [1/am] |
|------------|---------------|-----------------------|-----------------|-----------------|---------------------------------|
| Loviisa | Original | 95 000 | 12.83 | 40 | 3.3E-5 |
| | New addr. | 95 000 | 2.08 | 2 | 1.0E-5 |
| Olkiluoto | Original | 107 000 | 20 | 16 | 7.5E-6 |
| | New addr. | 107 000 | 1.08 | 1 | 8.7E-6 |

6.3 Failures of manual initiating devices

In Table 16 point estimates of failure rates of manual initiating devices are given for Finnish NPPs. In both power plants the number of devices was assumed the same in each of the units. From Loviisa the population derives from the new system only.

Table 16. Point estimates of failure frequency [1/a] of manual initiating devices in Finnish NPPs.

| NPP | System | Population | Time [a] | Failures | Failure frequency [1/a] |
|------------|---------------|-------------------|-----------------|-----------------|--------------------------------|
| Loviisa | Original | 839 | 12.83 | 26 | 2.4E-3 |
| | New addr. | 839 | 2.08 | 1 | 5.7E-4 |
| Olkiluoto | Original | 1066 | 20 | 16 | 7.5E-4 |
| | New addr. | 1066 | 1.08 | 2 | 1.7E-3 |

7. Discussion and conclusions

The title of this paper includes word reliability. It implies, that something quantitative of it would be presented. Although much data was presented, this has not been possible to carry out throughout. However, the subtitle specifies the study to exploration and analysis, which is well motivated, because this study is probably the first larger attempt in Finland to extract data on scientific basis from fire detection and alarm system installations. From nuclear power plants the failure reports were organised in a manner suitable for reliability analysis. Unfortunately, much laborious effort was needed for counting populations, and even then succeeding only partially.

From non-nuclear installations the number of installations was available rather accurately, but the count of populations of other components of the systems was based on a rather small sample, because it was difficult to obtain documents from the installations. From the point system analysis this sample remained too small and should be widened whenever possible. For failures inspection data base by SVK was extended covering long time and large population. Therefore a wide selection of different failures was observed. Drawbacks of that data base derived from the fact, that it was never designed, contrary to data from NPPs, from the viewpoint of reliability data collection. Interpretation of failure causes and severity classification from freely written records was difficult, and probably contains errors, because no systematic information from the site was available. Furthermore, instructions to inspectors were never very formal leading to varying level of sensitivity of failure detections, and sampling the installation population.

The classifications of failure severity were made from the system point of view by counting failures of components when possible. Since there are no established fault tree structures available for these installations, these component failure frequencies are intended to be used in the first round of iteration in the fault trees suggested here. It is possible, that analyses to be carried out later, might require considerable changes to these proposals either due to lacking statistical information from some proposed boxes, or due to internal structure of the system presumed too simple in this paper. Before these analyses become feasible, the point estimates of failure frequencies of the main components/subsystems are needed with error ranges for evaluating the relevance of observations. This requires reviewing some of the collected material from original records to fill the observed gaps in this pioneering work.

In a summary on the exploration of available failure data, there seemed to be available accurate records from NPPs, which were rather limited in component operational experience time, and less accurate material from non-nuclear installations, which covered both large populations and longer times. These two data sets combined will

give a rather good first view on the reliability problems of fire detection and alarm systems in Finland. This study must be taken as a collection of data. Further work is still needed to extract well quantified failure probabilities or frequencies for components or subsystems, as well as to set up relevant fault trees for practical use to evaluate the performance of the systems.

In Finland collection of reliability data has become more difficult as a result of the reform of regulations on inspection institutions, where SPEK lost its practical monopoly in controlling fire detection and alarm installation systems. Neither new regulations (law 562/1999) nor the bill in the parliament (by now law (468/2003)) do obligate collection of statistical data. The current authorities (especially TUKES) should take immediate actions to make sure, that fire detection and alarm installation statistics would be collected, for which 562/1999 gives a sufficient authorisation. For practical use these data should be stored in an electronic data base like PRONTO maintained by Ministry of the Interior for fire statistics. Furthermore, national guidelines are needed for fire detection and alarm installation inspectors for collection of relevant data, which in addition of the maintenance would also include the most important data needed to assess the reliability of these systems. (Added since the initial finishing of the typescript: Based on the law 468/2003 a decree by the Ministry of the Interior (SM A60) is still applied, which obligates inspecting bodies to collect information on performance of these installations and deliver them to TUKES. However, to our knowledge, no obligation to collect data in detail comparable to those treated here is set to any of the inspection bodies.)

8. Summary

A literature review of reliability data of fire detection and alarm systems was made resulting to rough estimates of some failure frequencies. The most extended study from Japan did, unfortunately, specify very accurately the sample, from which the data was collected. Two rather new sets of data from German NPPs were found in addition to some more general but older data. No theoretical or technical articles on the structure of reliability models of these installations were found.

Inspection records of fire detection and alarm system installations by SPEK were studied, and transferred in electronic data base classifying observed failures in symptom groups (59) and severity categories (3) guided by freely written records in the original data. Totally 11 253 installations and 17 154 inspection reports were included covering some 20 years of time. The results of that work are presented without many comments in tabular form in this paper.

A small sample of installations was collected, and number of components in them was counted to derive some distributions for determination of national populations of various components based on known total amount of installations.

From NPPs (Loviisa, Olkiluoto and Barsebäck) failure reports were analysed, and observed failures of fire detection and alarm systems were classified by severity and detection mode. They are presented here in tabular form for the original and new addressable systems. Populations were counted individually, but for all installations needed documents were not available. Therefore, presented failure frequencies are just first estimates, which will be refined later.

The study gave a detailed account on data available, but not yet sufficiently close the effort in the form of failure frequencies and fault trees, which are left to later studies of the problem.

References

- Abramowitz, M. & Stegun, I.A., 1970. Handbook of Mathematical Functions with Formulas, Graphs, and Mathematical Tables, U.S. Government Printing Office, Washington, D.C., xiv, 1046 p.
- Beers, Y., 1953. Introduction to the Theory of Error, Addison-Wesley, Cambridge, MA, 65 p.
- Berg, H.P., Hoffmann, H.H. & Röwekamp, M. 1997. Current status of quantitative fire risk assessment in German nuclear power plants, in Proceedings of ICONE 5, 5th International Conference on Nuclear Engineering, May 26 - 30, 1997, Nice, France, 8 p.
- Bukowski, R.W., Budnick, E.K. & Schemel, C.F. 1999. Estimates of the Operational Reliability of Fire Protection Systems, in Proceedings of the Third International Conference on Fire Research and Engineering, 4-8 October 1999, Chicago, IL, Society of Fire Protection Engineers, Bethesda, MD, USA, p. 87 - 98.
- Cholin, J.M. 1997. Fire Alarm Systems Inspection, Testing, and Maintenance, in A. E. Cote (ed.), Fire Protection Handbook, 18th Edition, National Fire Protection Association, Quincy, MA, Section 5, Chapter 5.
- CSNI 2000. Fire Risk Analysis, Fire Simulation, Fire Spreading and Impact of Smoke and Heat on Instrumentation Electronics, State-of-the-Art Report, NEA/CSNI/R(99)27, OECD Nuclear Energy Agency, Committee on the Safety of Nuclear Installations, Issy-les-Moulineaux, 99 p.
- Finucane, M. & Pinkney, D. 1989. Reliability of Fire Protection and Detection Systems, in Fire Safety Engineering - Proceedings of the 2nd International Conference, BHRA, The Fluid Engineering Centre, Cranfield, p. 211 - 234.
- FKS 1997. Fachbereich Kerntechnische Sicherheit, Daten zur Quantifizierung von Ereignisablaufdiagrammen und Fehlerbäumen, BfS-KT-Berichte BfS-KT-18/97, Bundesamt für Strahlenschutz, Saltzgitter, 110 p. + 19 p. App.
- FS 2002. Fire Statistics, Estimates, United Kingdom, 2001, National Statistics, Office of the Deputy Prime Minister, 17 December, 2002, 36 p.
- Green, A.E., 1982. High Risk Safety Technology, Wiley, Chichester, 654 p.
- Gupta, Y.P. 1984/85. Automatic Fire Detection Systems: Aspects of Reliability, Capability and Selection Criteria, Fire Safety Journal 8, 105 - 117.
- Hotta, H., 1995. An Example of Performance-based Design for Fire Protection System-New Sprinkler System, in Hasemi, Y. & Hayashi, Y. (Eds.), Fire Safety Design of Buildings and Fire Safety Engineering, Proceedings of the Mini-Symposium, June 12th, 1995, Tsukuba, BRI Proceedings No. 3, Building Research Institute, Japan, p. 61 - 80.

Høyland, A. & Rausand, M. 1994. System Reliability Theory - Models and Statistical Methods, Wiley, New York, 518 p.

Keski-Rahkonen, O., 2002. Fire safety research (FISRE) - FISRE summary report, in R. Kyrki-Rajamäki & E.K. Puska, (toim.), FINNUS - The Finnish Research Programme on Nuclear Power Plant Safety 1999-2002, Final Report, VTT Research Notes 2164, VTT, Espoo, p. 197 - 204.

Keski-Rahkonen, O., 2000. Fire safety research (FISRE), in T. Vanttola, E.K. Puska & A. Marttila (toim.), FINNUS - The Finnish Research Programme on Nuclear Power Plant Safety 1999-2002, Interim Report, VTT Research Notes 2057, VTT, Espoo, p. 70 - 79.

Kingswell, L.W. 1972. A post office system for the transmission of alarms, in Proceedings of the Symposium held at the Connaught Rooms, London, 8 - 10 March, 1972. Department of the Environment and Fire Occices' Committee, Her Majesty's Stationary Office, London 1974, p. 132 - 137.

Krasner, L.M., Ganti, C.S., Vincent, B.G., Samanta, P.K. & Boccio, J.L. 1985. Evaluation of Available Data for Probabilistic Risk Assessment (PRA) of Fire Events at Nuclear Power Plants, NUREG/CR-4231, U.S. Nuclear Regulatory Commission, Washington, D.C., 38 p. + 21 p. App.

Luck, H. 1972. A theoretical approach to optimizing the effectiveness of fire detection systems, in Proceedings of the Symposium held at the Connaught Rooms, London, 8 - 10 March, 1972. Department of the Environment and Fire Occices' Committee, Her Majesty's Stationary Office, London 1974, p. 148 - 152.

Luck, H.O., 1986. Correlation Filters for Automatic Fire Detection Systems, in Grant, C. E. & Pagni, P. J., (Eds), International Association for Fire Safety Science. Fire Safety Science. Proceedings. 1st International Symposium, October 7-11, 1985, Gaithersburg, MD, Hemisphere, New York, 1986, pp. 749-758.

McCormick, N.J. 1981. Reliability and Risk Analysis, Academic, Orlando, FA, 446 p.

Moliere, G. 1982. Securite des systemes de detection incendie, in Tagungsbericht AUBE'82. 8. Internationales Vortragsseminar über Probleme der automatischen Brandentdeckung, 5. bis 7. Oktober 1982, Universität Duisburg, p. 224 - 237.

NFPA 72, Standard for the Installation, Maintenance and Use of Local Protective Signaling Systems for Guard's Tour, Fire Alarm and Supervisory Service.

Nyyssönen, T. 2002. Paloilmoitintarkastuksissa havaitut laitteistojen viat [Failures in Fire Detection Systems Observed in Inspectations], Master's thesis, Helsinki University of Technology, Espoo, 91 p + 30 p. App., (in Finnish).

OREDA 1992. Offshore Reliability Data Handbook, OREDA Participants, Høvik, 2nd Edition, 614 p.

Rahikainen, J. & Keski-Rahkonen, O., 1998a. Determination of ignition frequency of fire in different premises in Finland, EUROFIRE '98, Fire Safety by Design Engineering & Management, Third European Symposium, Brussels, 11 - 13 March 1998.

Rahikainen, J. & Keski-Rahkonen, O. 1998b. Palojen syttymistaajuuksien tilastollinen määrittäminen, Palontorjuntatekniikka 28, no 2, s. 12-17.

Rahikainen, J. & Keski-Rahkonen, O. 2002. Statistical Determination of Ignition Frequency of Structural Fires in Different Premises in Finland, Fire Technology (julkaistavana).

Rajakko, J. 2002. Ydinvoimalaitosten paloilmoitinjärjestelmien luotettavuus [Reliability of Fire Alarming Systems in Nuclear Power Plants], Master's thesis, Helsinki University of Technology, Espoo, 62 p + 9 p. App., (in Finnish).

Ramachandran, S., 1999. Reliability Analysis Techniques to Improve Discrimination Between Fires and False Alarms, in Luck, H., (Ed.) International Conference on Automatic Fire Detection "AUBE'99", 11th. Proceedings. University of Duisburg. [Internationale Konferenz uber Automatischen Brandentdeckung.] March 16-18, 1999, Duisburg, Germany, pp. 354 - 364.

Ramachandran, G. 1993. Early Detection of Fire and Life Risk, Fire Engineers Journal, 53, No. 171, 33-37.

Ramachandran, G., 1992. Statistics Available in Different Countries for Fire Risk Evaluation. International Fire Information Conference. 1st. Proceedings. Cosponsored by International Fire Information Conference (IFIC) and international network for Fire Information and Reference Exchange (inFIRE). April 27-May 1, 1992, Moreton-in-Marsh, England, Society of Fire Protection Engineers, Boston, MA, Green, J. B.; Jason, N. H., Editors, 25-40 pp, 1993.

Ramachandran, G. 1998. The Economics of Fire Protection, E&FN Spon, London, 230 p.

Ramachandran, G. 1981a. Economic Value of Automatic Detectors, Fire Engineers Journal, 41, No. 122, 36-37.

Ramachandran, G. 1981b. Assessing the Economic Value of Automatic Fire Detectors, Fire, 73, No. 910, 556-557.

Ramachandran, G. 1980. Economic Value of Automatic Fire Detectors, BRE IP 27/80, Fire Research Station, Borehamwood, England, 4 p.

- Ramachandran, G. & Chandler, S. E. 1984. Economic Value of Early Detection of Fires in Industry and Commercial Premises, BRE IP 13/8, Building Research Establishment, Watford, England, 4 p.
- Rönty, V., Keski-Rahkonen, O. & Hassinen, J.-P., 2004. Reliability of sprinkler systems - Exploration and analysis of data from nuclear and non-nuclear installations, VTT Working Papers 15, VTT, Espoo, 89 p. + App. 9 p.
- Röwekamp, M. & Berg, H.- P. 2000. Reliability data collection for fire protection features, Kerntechnik 65, 102 - 107.
- Röwekamp, M., Riekert, T. & Sehrbrock, W. 1997. Ermittlung von Zuverlässigkeitskenngrößen für Brandschutzeinrichtungen in deutschen Kernkraftwerken, GRS-A-2456, Revision 1, Gesellschaft für Anlagen- und Reaktorsicherheit (GRS) mbH, 85 p.
- Sayers, B. 1972. An approach to the design of fire detection systems for quantitative reliability, in Proceedings of the Symposium held at the Connaught Rooms, London, 8 - 10 March, 1972. Department of the Environment and Fire Occices' Committee, Her Majesty's Stationary Office, London 1974, p. 140 - 145.
- SM A41, 1991. A:41 Ohje automaattisen paloilmittimen suunnittelusta ja asennuksesta, Sisäasiainministeriö, Pelastusosasto. (no more officially valid since September 1, 2001, replaced by SM A60).
- SM A60, 1999, A:60 Paloilmittimien hankinta, asennus, käyttöönotto, huolto, ja tarkastus, Dnro Sm-1999-440/Tu33, Sisäasiainministeriö, Pelastusosasto.
- T-Book 1992. Reliability Data of Components in Nordic Nuclear Power Plants, The ATV Office, Vällingby, 3rd Edition, 235 p.
- Tillander, K. & Keski-Rahkonen, O. 2001. Rakennusten syttymistäajuudet PRONTO-tietokannasta 1996 -1999 , VTT Research Notes, 2119. VTT Building and Transport, Espoo. 66 p. + App. 16 p., (in Finnish).
- Thomas, R.R., 1998. Analysis of USA retail fires, Fire Code Reform Research Program, Fire Code Reform Centre Limited, Australia, 107 p + App. 101 p.
- WASH-1400, 1975. Reactor Safety Study - An Assessment of Accident Risks in U.S. Commercial Nuclear Power Plants, WASH-1400 (NUREG-75/014), Washington, D.C.
- Watanabe, A., Sasaki, H. & Unoki, J., 1985. Overview on Fire Detection in Japan, in Grant, C. E. & Pagni, P. J., (Eds), International Association for Fire Safety Science. Fire Safety Science. Proceedings. 1st International Symposium, October 7-11, 1985, Gaithersburg, MD, Hemisphere, New York, 1986, pp. 679-688.
- Watanabe, A. 1979. Effectiveness of Active Fire Protection Systems. Teoksessa: U.S./Japan Government Cooperative Program on Natural Resources (UJNR). Fire

Research and Safety. 4th Joint Panel Meeting. February 5-9, 1979, Tokyo, Japan, 1979, s. 22-37.

Watson, L., Gamble, J. & Schofield, R. 2000. Fire Statistics, United Kingdom 1999, Home Office Statistical Bulletin 20/00, 91 p.

Wilson, D.K. 1997. Fire Alarm Systems, in A. E. Cote (ed.), Fire Protection Handbook, 18th Edition, National Fire Protection Association, Quincy, MA, Section 5, Chapter 1.

468/2003. Pelastuslaki [Rescue service act] 13.6.2003/468, Entry into force January 1, 2004.

562/1999. Laki pelastustoimen laitteiden teknisistä vaatimuksista ja tuotteiden paloturvallisuudesta (no more valid).

Öystilä, J. 1990. Automaattinen paloilmoin, Suomen Palotorjuntaliiton julkaisu, 77 s.

Appendix A: Detailed lists of system properties

Table A1. List of number of components of the original system in Olkiluoto OL2 unit.

| Component description | Sub A | Sub B | Sub C | Sub D | Total |
|--|-------|--------|--------|--------|--------|
| Protected floor area (m ²) | 7445 | 10 430 | 21 972 | 11 953 | 51 801 |
| Initiating circuits | 31 | 48 | 124 | 79 | 282 |
| Detectors | | | | | |
| - smoke | 95 | 106 | 301 | 209 | 711 |
| - heat | 179 | 343 | 771 | 291 | 1584 |
| Manual initiation devices | 65 | 94 | 226 | 142 | 527 |
| End-of-line resistors | 31 | 48 | 124 | 79 | 282 |

Table A2. List of number of components of new addressable systems in Loviisa and Olkiluoto

| Component description | Lo1 | Lo2 | OI1 | OI2 |
|---------------------------|------|------|------|------|
| MESA-control unit | 1 | 1 | | |
| ESA-control unit | 14 | 11 | 18 | 18 |
| Addresses | 2728 | 2171 | | |
| Fire zone configurations | 290 | 240 | 93 | 93 |
| Control panels | 125 | 77 | 63 | 58 |
| Address units | 147 | 194 | 113 | 89 |
| Detectors | | | a) | a) |
| - smoke ion | 993 | 888 | | |
| - smoke optical | 921 | 665 | 1400 | 1300 |
| - heat | 171 | 35 | 71 | 55 |
| - OMNI | | | 978 | 944 |
| Manual initiation device | 505 | 334 | 558 | 540 |
| Short circuit isolator | 132 | 132 | 305 | 282 |
| Alarm notification device | 5 | 0 | | |

a) Additionally some line detectors are also installed.

Table A3 Inventory of fire detection and alarm installation population, performed inspections, and their outcome annually.

| Year | Population | Inspections | Comissioning | | Renewal | | Periodic | | Alteration | |
|------|------------|-------------|--------------|-----|---------|-----|----------|-----|------------|-----|
| | | | Acc | Rej | Acc | Rej | Acc | Rej | Acc | Rej |
| 1980 | 2 378 | 11 | 2 | 1 | 2 | | | | | |
| 1981 | 2 651 | 13 | 2 | | | | 9 | 2 | | |
| 1982 | 2 995 | 6 | 1 | | | | 4 | | 1 | |
| 1983 | 3 401 | 15 | 12 | 1 | | | | | 2 | |
| 1984 | 3 823 | 17 | 1 | | 1 | | 11 | | | |
| 1985 | 4 229 | 21 | 5 | | 1 | | 12 | | 3 | |
| 1986 | 4 609 | 42 | 10 | 1 | 4 | | 21 | 2 | 4 | |
| 1987 | 5 102 | 65 | 22 | | 9 | 1 | 24 | 1 | 8 | |
| 1988 | 5 595 | 136 | 56 | | 13 | | 55 | | 12 | |
| 1989 | 6 102 | 276 | 69 | 4 | 31 | | 128 | 2 | 42 | |
| 1990 | 6 670 | 392 | 127 | 4 | 47 | 1 | 162 | | 51 | |
| 1991 | 7 302 | 602 | 192 | 8 | 65 | 1 | 261 | 2 | 73 | |
| 1992 | 7 846 | 665 | 187 | 7 | 69 | 2 | 331 | 3 | 64 | 2 |
| 1993 | 8 369 | 1139 | 247 | 6 | 92 | 4 | 667 | 2 | 120 | 1 |
| 1994 | 8 848 | 1120 | 283 | 2 | 77 | 2 | 621 | 4 | 131 | |
| 1995 | 9 368 | 1318 | 342 | 1 | 85 | 3 | 693 | 5 | 189 | |
| 1996 | 9 828 | 1357 | 320 | 9 | 111 | 4 | 686 | 8 | 213 | 3 |
| 1997 | 10 289 | 1276 | 334 | 8 | 109 | 4 | 553 | 10 | 254 | 2 |
| 1998 | 10 824 | 1625 | 409 | 15 | 124 | 2 | 710 | 10 | 346 | 7 |
| 1999 | 11 181 | 1150 | 305 | 14 | 53 | | 505 | 10 | 260 | 4 |

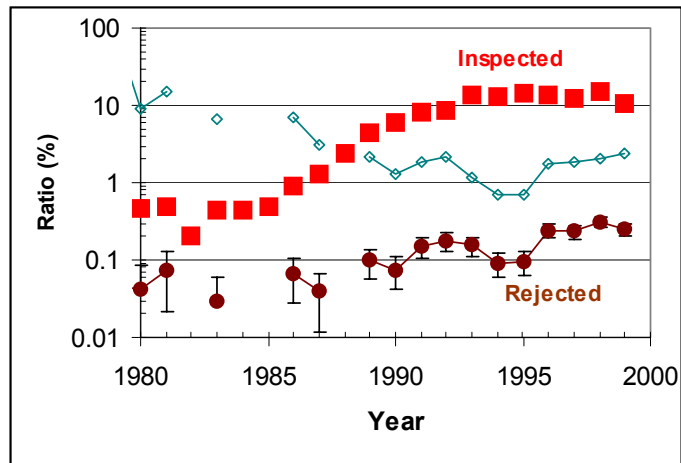

Figure A1. Ratio (%) of the number of inspections (squares), and number rejected cases (dots) to number of installations as well as ratio (%) of rejected to inspected installations (diamonds).

Table A4. Detector failure causes.

| Failure | Power plant and fire detection system | | | | | | | | |
|----------------------------------|---------------------------------------|----------|------------|-----------|-----------|------------|------------|------------|------------|
| | LoO | LoN | OIO | OIN | BaO | BaN | ToO | ToN | GrT |
| 1. Detector failure | 177 | 6 | 278 | 47 | 37 | 105 | 492 | 158 | 650 |
| <i>1.1 Dirty detector</i> | 4 | 2 | 130 | 29 | 5 | 8 | 139 | 39 | 178 |
| 1.1.1 Contaminated | 4 | 2 | 124 | 16 | 1 | 5 | 129 | 23 | 152 |
| 1.1.2 Ext. cause/faulty position | | | 6 | 13 | 4 | 3 | 10 | 16 | 26 |
| <i>1.2 Faulty detector</i> | 108 | 4 | 140 | 17 | 26 | 86 | 274 | 107 | 381 |
| 1.2.1 Damaged in use | 61 | 4 | 72 | 2 | 10 | 12 | 143 | 18 | 161 |
| 1.2.2 Unknown cause | 9 | | 19 | 8 | 1 | 3 | 29 | 11 | 40 |
| 1.2.3 Technical failure | 26 | | 39 | 6 | 14 | 69 | 79 | 75 | 154 |
| 1.2.4 Mechanical failure | 12 | | 10 | 1 | 1 | 2 | 23 | 3 | 26 |
| <i>1.3 Wet detector</i> | 65 | | 8 | 1 | 6 | 11 | 79 | 12 | 91 |
| 1.3.1 Opened/leaking sprinkler | 41 | | | | 3 | 2 | 44 | 2 | 46 |
| 1.3.2 Space damp | 24 | | 8 | 1 | 3 | 9 | 35 | 10 | 45 |

Table A5. Causes of failure in components.

| Failure | Power plant and fire detection system | | | | | | | | |
|--|---------------------------------------|----------|-----------|-----------|-----------|-----------|------------|-----------|------------|
| | LoO | LoN | OIO | OIN | BaO | BaN | ToO | ToN | GrT |
| 2. Failures in components | 180 | 7 | 77 | 11 | 11 | 14 | 268 | 32 | 300 |
| <i>2.1 Mechanical failure in CP</i> | 32 | 1 | 1 | | | 1 | 33 | 2 | 35 |
| 2.1.1 Mechanical damage | | 1 | 1 | | | | 1 | 1 | 2 |
| 2.1.2 Door switch/lock damage | 32 | | | | | 1 | 32 | 1 | 33 |
| <i>2.2 Electrical or electronic f.</i> | 122 | 5 | 60 | 9 | 11 | 12 | 193 | 26 | 219 |
| 2.2.1 Electronic failure | 27 | 2 | 31 | 9 | 11 | 12 | 69 | 23 | 92 |
| 2.2.2 Initiating circuit | 29 | | 1 | | | | 30 | | 30 |
| 2.2.3 Alarm notification | 25 | 1 | 2 | | | | 27 | 1 | 28 |
| 2.2.4 Indicator light bulb | 41 | 2 | 26 | | | | 67 | 2 | 69 |
| <i>2.3 Manual initiating device</i> | 26 | 1 | 16 | 2 | | 1 | 42 | 4 | 46 |
| 2.3.1 Technical failure | 15 | 1 | 8 | 1 | | 1 | 23 | 3 | 26 |
| 2.3.2 Mechanical failure | 11 | | 8 | 1 | | | 19 | 1 | 20 |

Table A6. Causes of failures in signal communication.

| Failure | Power plant and fire detection system | | | | | | | | |
|--------------------------------------|---------------------------------------|----------|-----------|-----------|----------|-----------|------------|-----------|------------|
| | LoO | LoN | OIO | OIN | BaO | BaN | ToO | ToN | GrT |
| 3. Failures in communication | 189 | 9 | 90 | 14 | 4 | 18 | 283 | 41 | 324 |
| <i>3.1 Wire/cable failure</i> | <i>40</i> | <i>2</i> | <i>16</i> | <i>1</i> | | <i>3</i> | <i>56</i> | <i>6</i> | <i>62</i> |
| 3.1.1 Were broken/loose | 25 | | 8 | | | 1 | 33 | 1 | 34 |
| 3.1.2 Installation f/bad conn. | 15 | 2 | 8 | 1 | | 2 | 23 | 5 | 28 |
| <i>3.2 No/bad connection to det.</i> | <i>36</i> | <i>4</i> | <i>31</i> | <i>9</i> | <i>4</i> | <i>12</i> | <i>71</i> | <i>25</i> | <i>96</i> |
| 3.2.1 Detector disconnected | 10 | | 13 | | 3 | 6 | 26 | 6 | 32 |
| 3.2.2 Address failure | | 3 | | 9 | | 4 | | 16 | 16 |
| 3.2.3 Detector bad contact | 26 | 1 | 18 | | 1 | 2 | 45 | 3 | 48 |
| <i>3.3 Announcement forwarding</i> | <i>21</i> | <i>3</i> | <i>11</i> | <i>3</i> | | <i>2</i> | <i>32</i> | <i>8</i> | <i>40</i> |
| <i>3.4 Removed circuit</i> | <i>60</i> | | <i>21</i> | <i>1</i> | | | <i>81</i> | <i>1</i> | <i>82</i> |
| 3.4.1 Cause unkn./not found | 57 | | 21 | 1 | | | 78 | 1 | 79 |
| 3.4.2 External cause | 3 | | | | | | 3 | | 3 |
| <i>3.5 Ground short</i> | <i>32</i> | | <i>11</i> | | | <i>1</i> | <i>43</i> | <i>1</i> | <i>44</i> |
| 3.5.1 Bad grounding | 11 | | 5 | | | 1 | 16 | 1 | 17 |
| 3.5.2 Cause external/unknown | 21 | | 6 | | | | 27 | | 27 |

Table A7. Causes of failures in auxiliary control subsystems.

| Failure | Power plant and fire detection system | | | | | | | | |
|--|---------------------------------------|----------|----------|-----|-----|----------|-----------|-----------|-----------|
| | LoO | LoN | OIO | OIN | BaO | BaN | ToO | ToN | GrT |
| 4. Failure in auxiliary control | 7 | 5 | 7 | | | 6 | 14 | 11 | 25 |
| 4.1 Failure in computer/coding | | 4 | | | | 5 | | 9 | 9 |
| 4.2 Control of fire dampers | 2 | | 3 | | | | 5 | | 5 |
| 4.3 Control in extinguishing | 2 | | 1 | | | 1 | 3 | 1 | 4 |
| 4.4 Control of fire pumps | | 1 | 3 | | | | 3 | 1 | 4 |
| 4.5 Alarming/notification appl. | 3 | | | | | | 3 | | 3 |

Table A8. Causes of failures in power supplies.

| Failure | Power plant and fire detection system | | | | | | | | |
|--|---------------------------------------|----------|-----------|----------|----------|----------|-----------|-----------|-----------|
| | LoO | LoN | OIO | OIN | BaO | BaN | ToO | ToN | GrT |
| 5. Failure in power supply | 19 | 6 | 15 | 2 | 1 | 5 | 35 | 13 | 48 |
| 5.1 Failures in mains voltage or circuit current | 12 | 4 | 4 | 1 | | | 16 | 5 | 21 |
| 5.2 Failures in stanby batteries | 2 | | 7 | 1 | 1 | 3 | 10 | 4 | 14 |
| 5.3 Faulty component/ connection | 5 | 2 | 4 | | | 2 | 9 | 4 | 13 |

Table A9. Causes of false alarms.

| Failure | Power plant and fire detection system | | | | | | | | |
|------------------------------------|---------------------------------------|-----|----------|----------|-----|-----|-----------|----------|-----------|
| | LoO | LoN | OIO | OIN | BaO | BaN | ToO | ToN | GrT |
| 6. False alarms | 28 | | 7 | 3 | | | 35 | 3 | 38 |
| <i>6.1 Human error</i> | <i>21</i> | | <i>5</i> | <i>2</i> | | | <i>26</i> | <i>2</i> | <i>28</i> |
| 6.1.1 Communication error | 1 | | 2 | 1 | | | 3 | 1 | 4 |
| 6.1.2 Control error | 11 | | 2 | 1 | | | 13 | 1 | 14 |
| 6.1.3 Testing error | 9 | | 1 | | | | 10 | | 10 |
| <i>6.2 Instruction error</i> | <i>7</i> | | <i>2</i> | <i>1</i> | | | <i>9</i> | <i>1</i> | <i>10</i> |
| 6.2.1 Insufficient/faulty guidance | 5 | | 1 | | | | 6 | | 6 |
| 6.2.2 Design error, modification | 2 | | 1 | 1 | | | 3 | 1 | 4 |

VTT WORKING PAPERS

VTT RAKENNUS- JA YHDYSKUNTATEKNIikka – VTT BYGG OCH TRANSPORT – VTT BUILDING AND TRANSPORT

- 4 Hietaniemi, Jukka, Hostikka, Simo & Vaari, Jukka. FDS simulation of fire spread - comparison of model results with experimental data. 2004. 46 p. + app. 6 p.
- 6 Viitanen, Hannu. Betonin ja siihen liittyvien materiaalien homehtumisen kriittiset olosuhteet - betonin homeenkesto. 2004. 25 s.
- 7 Gerlander, Riitta & Koivu, Tapio. Asiantuntijapalvelu yritysten innovaatiojohtamisen kehittämiseksi Piilaakson osaamiseen tukeutuen. IMIT SV –hankkeen loppuraportti. 2004. 25 s. + liitt. 11 s.
- 11 Lakka, Antti. Rakennustyömaan tuottavuus. 2004. 26 s. + liitt. 15 s.
- 14 Koivu, Tapio, Tukiainen, Sampo, Nummelin, Johanna, Atkin, Brian & Tainio, Risto. Institutional complexity affecting the outcomes of global projects. 2004. 59 p. + app. 2 p.
- 15 Rönty, Vesa, Keski-Rahkonen, Olavi & Hassinen, Jukka-Pekka. Reliability of sprinkler systems. Exploration and analysis of data from nuclear and non-nuclear installations. 2004. 89 p. + app. 9 p.
- 18 Nyssönen, Teemu, Rajakko, Jaana & Keski-Rahkonen, Olavi. On the reliability of fire detection and alarm systems. Exploration and analysis of data from nuclear and non-nuclear installations. 2005. 62 p. + app. 6 p.